

# Alba 2017 Sustainability Report

Moving towards a more sustainable future







**His Royal Highness  
Prince Khalifa  
bin Salman Al Khalifa**

The Prime Minister of the  
Kingdom of Bahrain



**His Majesty King  
Hamad bin Isa Al Khalifa**

The King of the  
Kingdom of Bahrain



**His Royal Highness  
Prince Salman  
bin Hamad Al Khalifa**

The Crown Prince, Deputy  
Supreme Commander  
and First Deputy  
Prime Minister of the  
Kingdom of Bahrain



# Contents

---

A Message from Tim Murray Chief Executive Officer	6
About this Report	7
About Aluminium Bahrain	8
Our History	8
Our Operations	9
Our Products	10
Our Markets	11
Economic Performance	12
Stakeholder Engagement	14
Reporting on Material Issues	16
Awards	17
External Initiatives	17
Memberships and Committees	17
<b>Our Strategy</b>	<b>18</b>
Sustainable Development Goals	18
Principal Risks and Uncertainties	19
Our Key Performance Areas	19
Opportunities for Growth	20
<b>Governance and Ethics</b>	<b>22</b>
Governance	22
Committees	23
Ethics and integrity	23
Environmental, Social and Economic Compliance	26
<b>Our Supply Chain</b>	<b>28</b>
Sustainable Procurement	28
<b>Our Responsibility for the Environment</b>	<b>30</b>
The Aluminium Manufacturing Process	31
Materials	32
Energy	36
Water	38
Emissions	40
Effluents and Waste	42
<b>Our Responsibility for People</b>	<b>44</b>
Vision 2030	44
Occupational Health and Safety	44
Employment Conditions and Benefits	48
Employee Data	50
Human Rights	52
Training and Education	53
Labour and Management Relations	55
<b>Glossary</b>	<b>56</b>
<b>GRI Content Index</b>	<b>58</b>

## A Message from Tim Murray Chief Executive Officer

As the Chief Executive Officer of Alba, I believe that our sustainability performance is nicely progressing. We have been conducting our business safely and responsibly. Our highest priority, in all times, remains the safety and wellbeing of our workers. To that extent, I am proud that Alba achieved Zero Fatality and has been reducing its number of recordable injuries over the last five years.

2017 was a successful year for Alba on many fronts despite the setbacks from the power outage incident in April 2017. Overall, our performance reflected our resilience in setting the benchmark on Line 5 recovery, our good control over expenses as well as top-line revenues. In addition, thanks to our geographical footprint and the focused-approach of our marketing team, we were able to increase our yearly sales. In terms of Safety, we believe that our positive optimism to always raise safe behaviours in the workplace is a force multiplier as we were able to finish the summer season without any cases of heat exhaustion.

We continue to have extraordinary support from all Alba employees, Management and Contractors towards a better Safety, Health and Environment system for Alba.

As part of our Environmental Responsibility, Alba is continuously looking to reduce the environmental footprint associated with its existing operations. The Company has a robust Health, Social and Environment Management System to ensure that all processes are developed responsibly.

I am a firm believer that we can always do more than we think; as such, we constantly seek to engage cutting-edge technologies and solutions as well as best management methods to ensure we use our resources efficiently and reduce our environmental footprint. With the Line 6 Expansion Project in full swing - Line 6 smelter & Power Station 5 - Alba is further committed to meet the



international standards of the Equator Principles (EP) and International Finance Corporation (IFC) on top of meeting Bahrain's Supreme Council of Environment (SCE) requirements. By investing in technology and innovation, we believe that we will contribute to the health of our society and the communities we serve.

Social impact and sustainability will remain integral to Alba to ensure that we generate a positive impact for all our stakeholders. We are committed to maximising the value to our shareholders and stakeholders alike by investing and capitalising on our human resources, optimising production abilities, focusing on efficiency and most importantly, staying strong on our Safety core-values.

We want to create safe and healthy workplaces for everyone. Sustainability isn't an add-on for our Company; it is a long-term commitment to be an eco-friendly smelter and contribute towards a greener Bahrain. I thank our employees, customers and our partners for being with us in this journey and for their valuable feedback which will help us to further develop the sustainable goals of our Company.

Tim Murray  
Chief Executive Officer

## About this Report

---

This report is Aluminium Bahrain B.S.C.'s (Alba) second Global Reporting Initiative (GRI) sustainability report and the FIRST aligned with the Global Reporting Initiative (GRI) Standards.

The report provides an overview of Alba's performance on material topics for the Full-Year (FY) 2017 (1st January, 2017 to 31st December, 2017). We will continue to report to the GRI Standards annually. Where possible we have provided comparative data for a five year period to show relevant performance trends. All data is related to Alba's operations located in Bahrain.

This report has been prepared in accordance with the GRI Standards: Core option and the GRI G4 Mining and Metals Sector Disclosures. External assurance was not conducted specifically for this report. Alba's financials are audited by Ernst & Young (EY).

Safety Health and Environment statistics are audited annually against ISO standards. An independent environmental and social consultant audits the Line 6 Expansion Project twice per year during the construction phase and will continue with annual audits during the operational phase of Line 6 until completion of the loan service.

We have incorporated the GRI Reporting Principles for Report Content as follows:

- Internal stakeholders were engaged in the materiality assessment and the outcomes of external stakeholder engagement inform the management approach for the Line 6 project (GRI Principle 'Stakeholder Inclusiveness')
- The materiality assessment included topics related to the broader context of sustainability within the minerals sector and business in general (GRI Principle 'Sustainability Context')
- Internal stakeholders took part in identifying material topics; stories and data relate to these material topics - (GRI Principle 'Materiality')
- Topics reported include those that have been assessed as significant to Alba and the aluminium sector. This will enable stakeholders to make informed decisions on Alba's sustainability performance. Boundaries have been defined for all topics. - (GRI Principle 'Completeness')

## About Aluminium Bahrain

Aluminium Bahrain B.S.C. (Alba) is one of the largest and most modern aluminium smelters in the world. Known for its technological strength and innovative policies, Alba enforces strict environmental guidelines, maintains a high track record for safety, and is widely regarded as one of the top performers on a global scale.

Alba supports numerous community oriented programmes and social activities that have underlined its status as one of Bahrain's leading industrial organisations that remains committed towards upholding its corporate social responsibilities. Alba's inception marked the beginning of Bahrain's strategy to diversify its economic base and reduce its dependence on oil. The aim was to establish an industry that would provide valuable export earnings, develop the country's resources and create training and employment opportunities for a large number of Bahrainis.

Alba's early success established a blueprint for other non-oil industries to follow, including a thriving downstream aluminium industry. Today, Alba is a major contributor to the social, industrial and economic development of the Kingdom of Bahrain, and has an employee base of 2,700.

Alba is a dual listed Company on the Bahrain Bourse and London Stock Exchange. Primary shareholders are the Bahrain Mumtalakat Holdings Company (69.38%), the SABIC Industrial Investment Company (20.62%) and 10% is held by the general public.

Headquarters are located in Manama, Bahrain, and operations are solely in the Kingdom of Bahrain.

## Our History

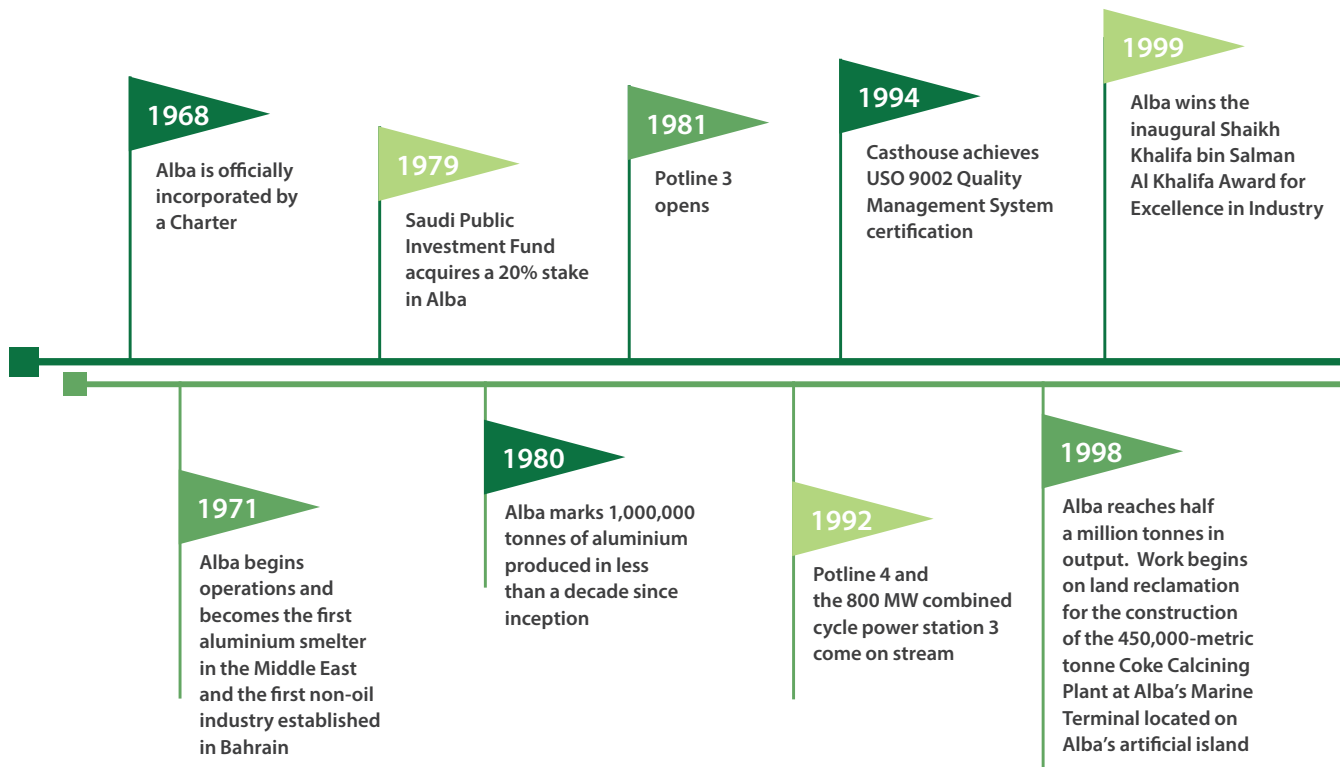



## Our Operations

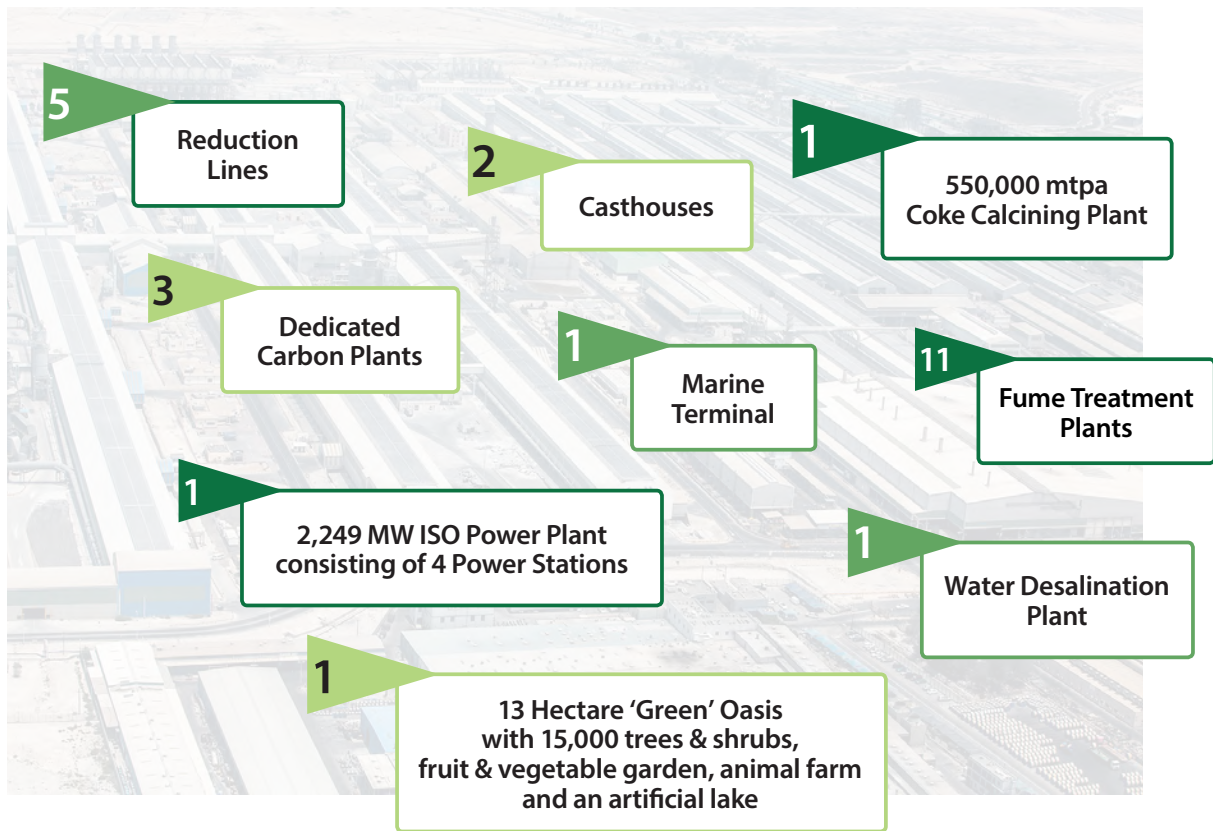

2005

The new 1.5km Potline 5 becomes the world's longest reduction line facility

2012

Potline 5 capacity increased to 360 kA

2015

Alba shareholders approve Line 6 Expansion Project during Extraordinary General Meeting (EGM)

2017

Alba is the recipient of the inaugural Bahrain-US Free Trade Agreement (FTA) Award by Bahrain's Economic Development Board in cooperation with the American Chamber of Commerce and the US Bahrain Business Council

2000

Alba wins the United Nations Millennium Business Award for Environmental Achievement; ISO14001 Environmental Management System accreditation

2010

Alba launches first IPO and is listed on the Bahrain Bourse and the London Stock Exchange

2013

Rectifiers Replacement Project completed - one of the first brown field projects of this magnitude anywhere in the world

2016

USD \$1.5 billion syndicated loan closed, the first tranche of the Company's funding plan for the Line 6 project. An all-time production record of 971,420 metric tonnes is set

## Our Products

### Standard Ingots

Standard ingots are re-melted at the customer furnaces and then cast to produce a wide variety of end products covering the entire spectrum of aluminium applications from the construction industry, transportation, electrical goods to household appliances

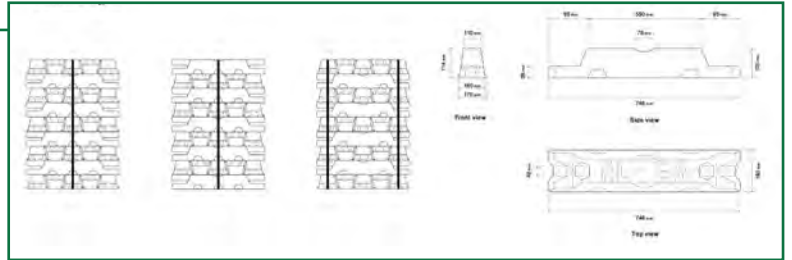

### High Quality Sheet Ingots (Rolling Slabs)

Used for finished products such as ultra light gauge foils and cookware foil. Lithographic applications include producing offset printing plates. Used in the packaging industry, transport and aviation industries, construction and general engineering applications such as panelling, flooring and roofing.

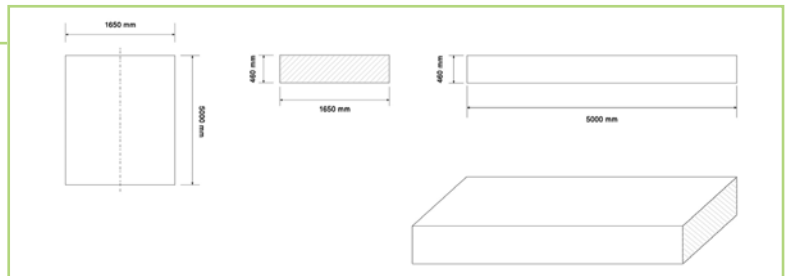

### Foundry Alloyed Ingots

Primarily used by the automotive industry for manufacturing high quality automotive wheels, truck hubs and gas pump nozzles.

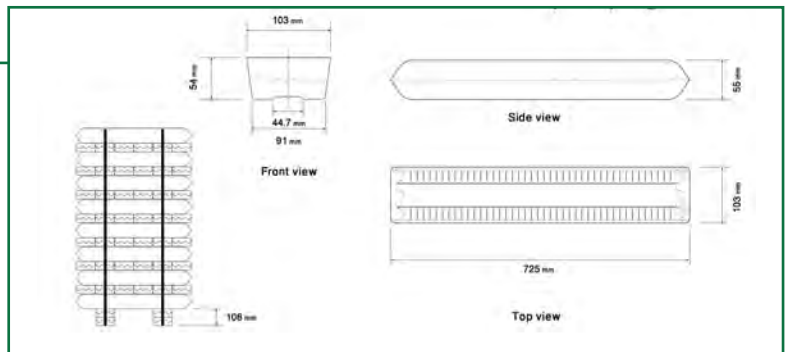

### Liquid Metal

Converted into a range of value added products such as primary aluminium alloys and master alloys. Used to produce primary aluminium based electrical conductor (EC) rods, alloy rods, and wire and alloy ingots; other applications include aluminium powder and aluminium pellets, aluminium wires for electrical and mechanical use, curved line conductors, aluminium clad steel (ACS) wires for transmission lines, solid conductors and aluminium casting for cars and trucks wheels.

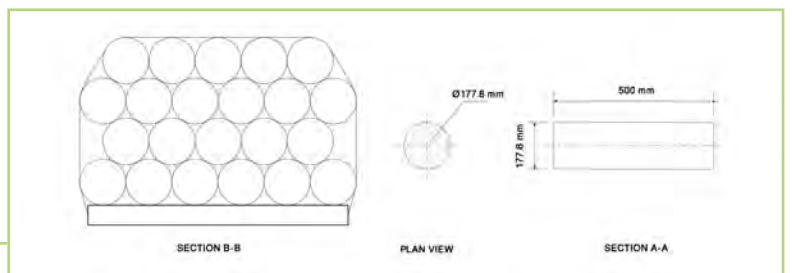

### Extrusion Billets

Soft alloys are used for architectural applications, building and kitchen suite sections. Hard alloys are used in a variety of engineering and transport applications.

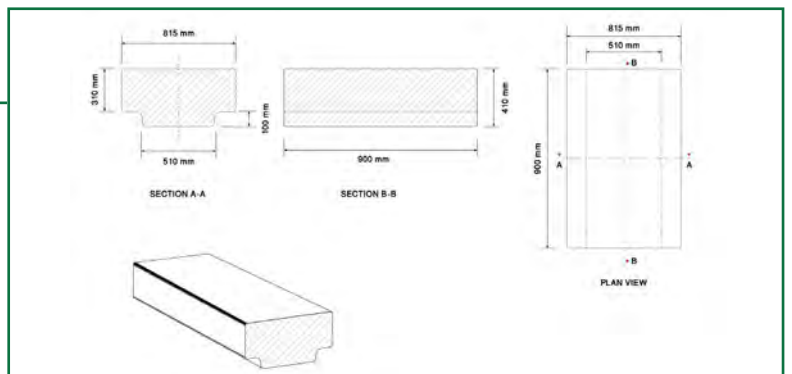

### T-Ingots

T-ingots are re-melted to produce a wide variety of end products including for the construction industry, transportation, electrical goods and household appliances.

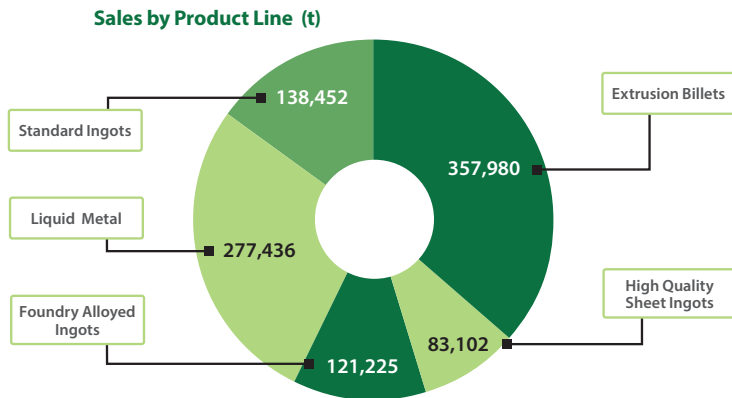
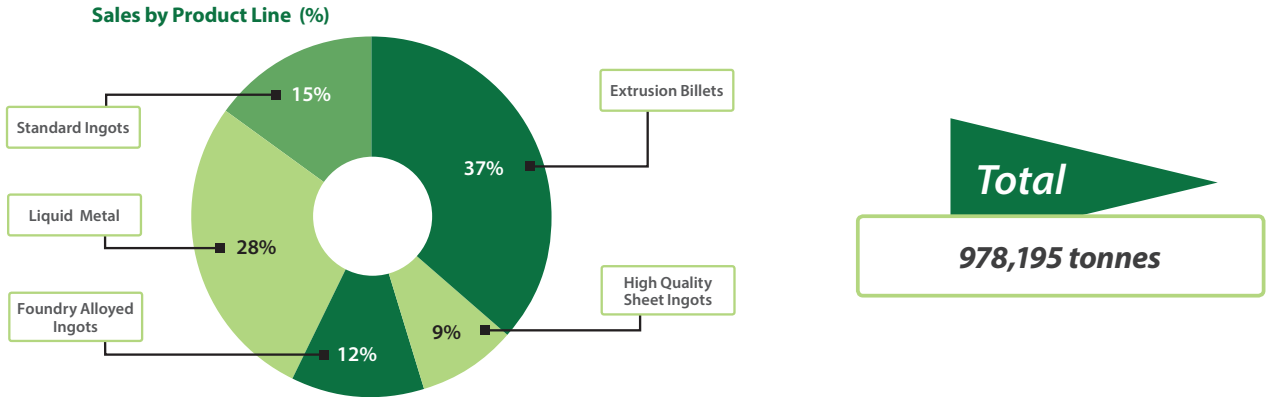

## Our Markets

The metal produced at Aluminium Bahrain B.S.C. (Alba) is exported across the globe to more than 25 countries and even into outer space. In 1997, Alba's aluminium was used for producing the solar panels on "Sojourner" rover used in the Mars Pathfinder spacecraft.

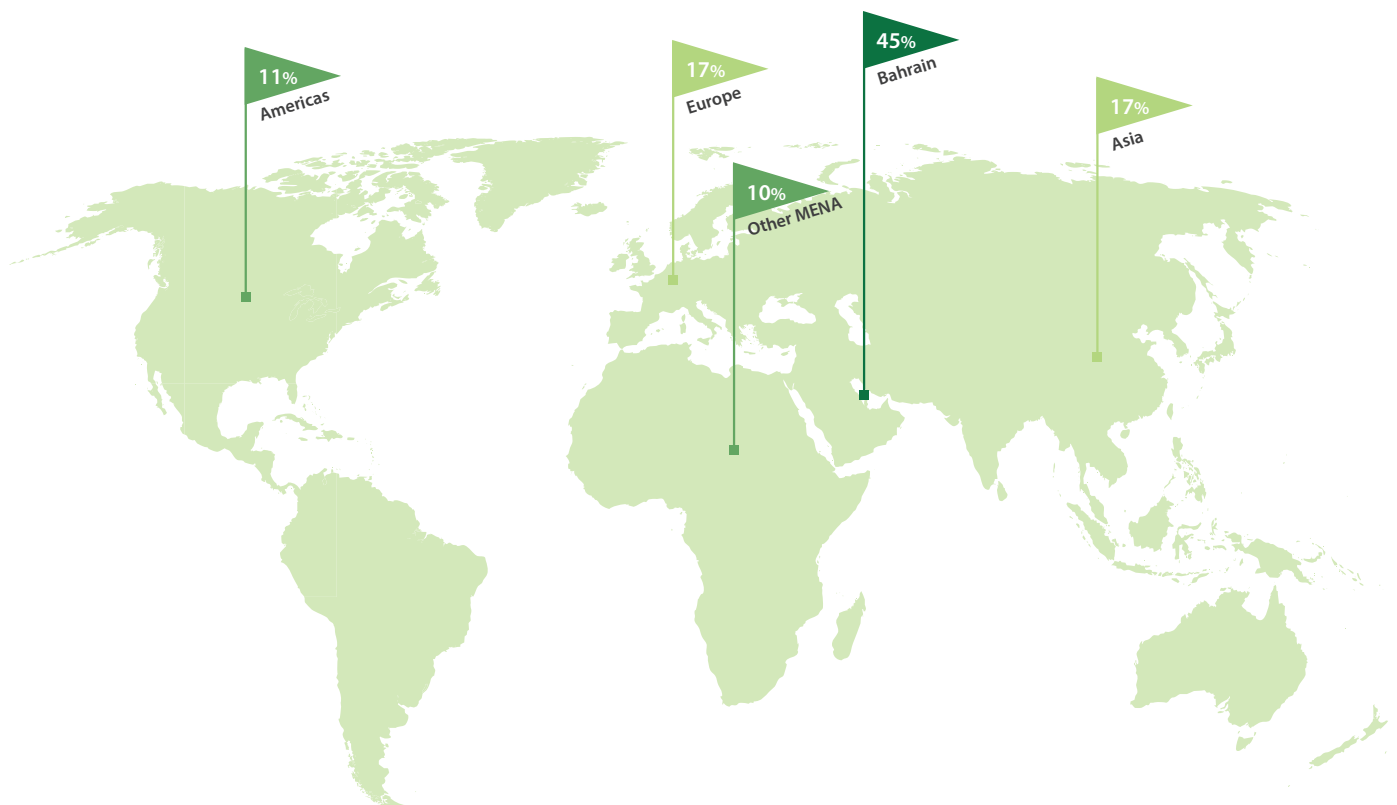

## Economic Performance

Aluminium Bahrain B.S.C (Alba) presents its financial results as per the International Financial Reporting Standards (IFRS) accounting rules. Given the nature of the business and in line with our peers in the industry, the Company also reports EBITDA.

Alba fulfils the requirements of its local regulators to include Bahrain Bourse; the Central Bank of Bahrain; Ministry of Industry, Commerce and Tourism (MOICT) as well as London Stock Exchange via its GDR listing. Audits are undertaken on a quarterly basis and on annual basis by Ernst & Young.

### BD '000'

	Y2017	Y2016
Operating Costs	600,815	459,283
Employee Wages and Benefits	96,465	86,526
Payment to Lenders	2,149	2,504
Payments to Government	4,981	4,465
<b>Total</b>	<b>704,410</b>	<b>552,778</b>
Depreciation	67,843	71,581
Derivatives	503	0
Others	68,346	71,851
Revenue	857,762	669,760
Other Income	7,451	2,989
Total revenues	865,213	672,749
<b>Net Income</b>	<b>92,457</b>	<b>48,390</b>

### US\$ '000'

	Y2017	Y2016
Operating Costs	1,597,913	1,221,498
Employee Wages and Benefits	256,556	230,122
Payment to Lenders	5,715	6,660
Payments to Government	13,247	11,875
<b>Total</b>	<b>1,873,432</b>	<b>1,470,155</b>
Depreciation	180,433	190,374
Derivatives	1337.766	0
Others	181,770	190,374
Revenue	2,281,282	1,781,277
Other Income	19,816	7,949
Total revenues	2,301,098	1,789,226
<b>Net Income</b>	<b>245,896</b>	<b>128,697</b>

	US\$ Million	BD Million
EBITDA 2017	437	164
EBITDA 2016	326	123

	%
EBITDA 2017	19%
EBITDA 2016	18%

Earnings per Share	
EPS 2017	0.17
EPS 2016	0.09



## Stakeholder Engagement

Prior to the Line 6 Expansion Project, stakeholder engagement initiatives were limited to existing Bahraini practices and largely focused on government authorities responsible for regulating the Aluminium Bahrain B.S.C. (Alba) operations. However, the financing requirements for Alba's Line 6 Expansion Project required that Alba meet the conditions of the International Financing Corporation (IFC) Performance Standards and Equator Principles III - June 2013, which are backed by the World Bank Environmental, Health and Safety Guidelines.

Following an external consultant's review of the Environment and Social Impact Assessment (ESIA) for the Line 6 Project in 2016 to determine Alba's compliance with IFC Standards, an Environmental and Social Action Plan (ESAP) was developed in March 2016 to reflect the additional IFC requirements. Following completion of the ESIA, the project design was further developed and improved, which required further environmental and social impact assessment studies to be undertaken to update the original ESIA with additional information and address many of the ESAP requirements as per the IFC and lenders requirements. In response to this, a supplementary ESIA was undertaken by Alba, which was approved in December 2017.

Both the ESIA and the Supplementary ESIA give complete details on the environment and social impacts of the Line 6 project and are available at <http://www.Albasmelter.com/About%20Alba/Pages/Line6.aspx>

Alba is developing a project-wide Stakeholder Engagement Plan (SEP), which includes the following objectives:

- Outline the stakeholder engagement requirements as per Bahraini legislation
- Provide guidance for stakeholder engagement so that it meets the standards of international best practice requirements of the IFC and Equator Principles
- Identify key stakeholders that are affected, and/or able to influence Alba, the Line 6 project and its activities
- Identify the most effective methods and structures to disseminate Line 6 project information and consult with and gather feedback from affected stakeholders
- Identify effective stakeholder engagement techniques to address all stakeholders
- Identify and develop measures to effectively mitigate Environmental and Social (E&S) risks that are likely to arise from the Line 6 project through stakeholder consultation and engagement
- Include a formal external grievance mechanism plan for stakeholders and public to raise any concerns, provide feedback and comments about Alba, and



- Define and develop a periodic reporting and monitoring measuring system to ensure the effectiveness of the SEP.

The SEP is available at: <http://www.albasmelter.com/Corporate%20Responsibility/CSR/Documents/Alba%20Stakeholder%20Engagement%20Plan%20Version%201.pdf>

Alba so far has established a working Stakeholder Engagement Management group in collaboration with Alba's Line 6 Expansion teams i.e. Potline 6 and Power Station 5 and their respective contractors.

This group focuses on stakeholder engagement as outlined in the 2017 Supplementary ESIA. A Stakeholders Exhibitions Meeting will be held for various stakeholder groups to communicate the environmental and social impacts of the Line 6 project as well as receive feedback from the stakeholders. The outcomes of this meeting will be analysed and used to formulate further stakeholder engagement activities.

Alba's key stakeholder groups for the Line 6 Expansion Project are:

#### Government of Bahrain and its Entities

This group has the control to regulate or influence Alba's operations and the Line 6 project in terms of establishing policies, granting permits or other approvals and monitoring and enforcing compliance with Bahrain laws.

#### Shareholders

Bahrain Mumtalakat Holding Company, SABIC Investment Company and the general public. The first two shareholders influence the decisions of the Company and affects the way in which Alba operates.

#### South Alba Industrial Estate (SAIE)

SAIE is one of the seven industrial areas in Bahrain comprising a cluster of industrial and commercial companies including local entrepreneurs and businesses in the immediate Line 6 project area and businesses who may gain benefits by providing goods and services to Alba for the project.

#### Local Communities

Alba is one of the key industrial companies in Bahrain. It must continue its commitment to being a socially responsible employer that offers employment opportunities to Bahrainis.

#### Employees

This group implements the Company's decisions thereby influencing the profitability of Alba, and is also directly affected by Alba's business decisions.

#### Customers (Local and Global)

Alba has a strong customer base in Bahrain due to its solid business ties with the downstream industry. Around 50 per cent of Alba's output is supplied to Bahrain's downstream aluminium industry, with the remainder exported to regional and international customers in the Middle East, Europe, Far East, South East Asia, Africa, and North America.



## Reporting on Material Issues

To prepare for the compilation of Aluminium Bahrain B.S.C.'s (Alba) FY 2017 Sustainability Report, a formal materiality assessment was completed using the online Materiality Assessment Tool (MAT).

The MAT was undertaken by 10 at the CXO level and 42 Alba managers to identify the sustainability issues which are most material to the organisation and themselves.

In addition to the material topics identified in the assessment, we have also included reporting on effluents and waste, and human rights, as, although these were not identified as material in the assessment, are indeed material issues for Aluminum Bahrain B.S.C. and the broader mining and metals industry.

### ALBA'S MOST MATERIAL TOPICS

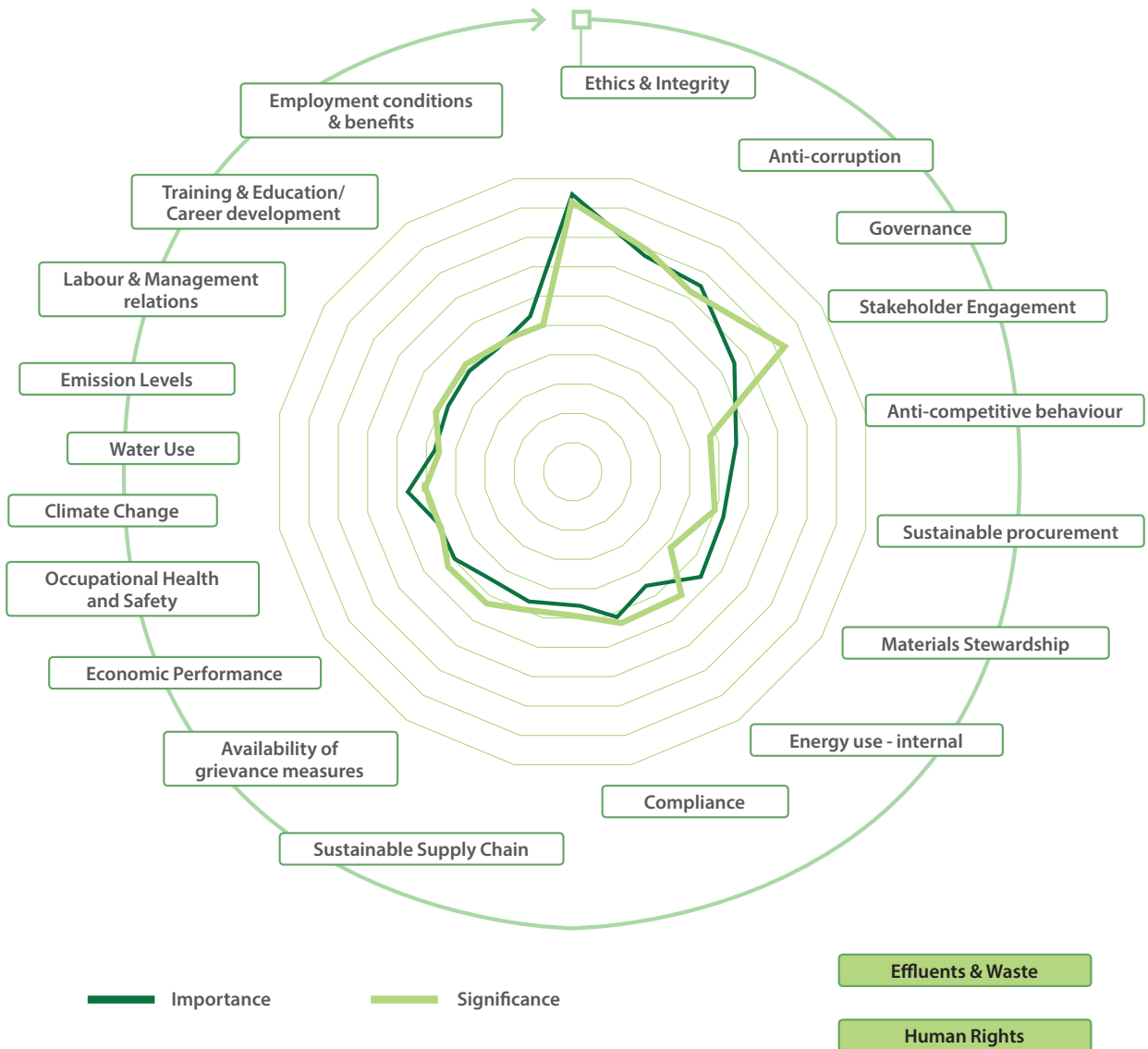

This chart is read from top middle, following in a clockwise direction



## Awards

- Aluminium Bahrain B.S.C. (Alba) was the recipient of the '**Leading Corporate for Investor Relations – Bahrain**' at the Middle East Investor Relations Association's (MIERA) 2017 IR Awards. The award recognises the performance of corporate and individual Investor Relations (IR) professionals in the Gulf Cooperation Council (GCC) region.
- Alba was the proud winner of the **2017 Occupational Excellence Achievement Award** and the **2017 Significant Improvement Award** by the National Safety Council (NSC) – USA. These wins endorse the Company's long-standing commitment to safety as well as its efforts in creating a safe working environment for its employees and contractors alike.
- Alba was awarded the much coveted British Safety Council's **International Safety Award with Merit** for the year of 2017 in recognition for its commitment towards the health, safety and wellbeing of its workforce during 2016.
- Alba is the proud winner of the **Gold Award for Occupational Health and Safety 2017** by the Royal Society for the Prevention of Accidents (RoSPA), UK. Alba Senior SHE Manager Moh'd Khalil has been honoured with the RoSPA 2017 Guardian Angel Award for his exceptional commitment and contribution towards the safety and health of Alba employees.
- Alba won the **Ethical Boardroom Corporate Governance 2017 Award** in the Middle East. The Award recognised Alba for its outstanding corporate governance policies as well as maintaining good practices in accountability and transparency in the region.
- Alba is the proud winner of the **2017 Most Innovative Aluminium Solutions GCC Award**, from CFI.co, for adhering to the highest environmental, social and governance (ESG) standards and for its efforts towards supporting a thriving downstream aluminium industry, both locally and overseas.

## External Initiatives

As a result of lender requirements (World Bank) for the Line 6 Expansion Project (Line 6 smelter and Power Station 5), Alba has become more involved in external initiatives to understand and mitigate the environmental and social impact of operations, as outlined in the recently prepared Line 6 Stakeholder Engagement Plan (SEP), which the company made public by December-end 2017.

Historically, external initiatives beyond the company's operations have been limited and at a low scale; however, this is gradually evolving with custom-made programs such as our involvement

with the local school where we have installed air monitoring equipment to confirm that the children and staff experience no health risks.

In addition, Alba is also well placed to support the local community by supplying potable water from the desalination plant and the backup power should the Government need to draw on the company's spare capacity to meet the community's needs.

## Memberships and Committees

- International Aluminium Institute
- Gulf Aluminium Council
- Aluminium Association (USA)
- Aluminium Extruders Council (USA)

## Our Strategy

### Market Conditions

Further improvements in the global labour market, coupled with the continuous accommodative monetary policies in major economies have led to a stable global economy in 2017. The London Metal Exchange (LME) aluminium price increased by 33% Year-over-Year (YoY) due to China winter closures on the back of pollution crack-down, increase in overall smelter operating costs and decline in inventories outside China.

World consumption hit a new record of 63.6 million metric tonnes, up by 6% YoY while world production stood at 63.5 million metric tonnes, an increase of 8% YoY. Chinese supply continued to surge (36.3 million metric tonnes, up by 13% YoY) on the back of the new smelters' restart to offset closures while Chinese consumption stood at 34.4 million metric tonnes in 2017. China had a strong finish in terms of its reported stocks in 2017. Continuous drawdown of inventories would cause tightness in the global market. Aluminium stocks in LME-registered warehouses stood at 1.1 million by year-end, down by 50% YoY.

Aluminium Bahrain B.S.C.'s (Alba) diligent marketing strategy has allowed the Company to tap into high netbacks' markets as well as to sell its product portfolio in Bahrain (local downstream), MENA (neighbouring countries), Asia, Europe and the Americas.

### Climate Change

Over the last decade, the Kingdom of Bahrain has taken great strides to comply with the climate change obligations of the United Nations Framework Convention on Climate Change (UNFCCC). In its endeavours to uphold its commitments towards climate change, the Kingdom of Bahrain is working on the Third National Communication Report (the first and second communication reports can be viewed at: <http://www.sce.gov.bh/en/ClimateActioninBahrain?cms=iQRpheuphYtJ6pyXUGiNqvAiK8jAcW4>). Many initiatives have started to take place namely in the integration of sea-level rise considerations into national development policies and furthering ecosystem protection initiatives to promote climate resilience.

The Kingdom of Bahrain became a signatory of the Convention in June 1992 and ratified the Kyoto Protocol in January 2006 with no further commitments.

As a member of the Small Island Developing States (SIDS), Bahrain has special considerations primarily due to the increased vulnerabilities and relatively limited capacities that islands face. Bahrain is a Party Member to the Paris Agreement. In the negotiations process, Bahrain is a member of the Group of 77 and China (G77 & China) which represent the concerns of 134 developing country Parties and is currently chaired by South Africa.

Bahrain is also a member of the Arab Group which represents 22 members of the League of Arab States and is currently chaired by Saudi Arabia. Towards the new agreement, The Kingdom of Bahrain has represented the Arab Group on Adaptation Climate Finance issues. Currently, Bahrain represents the G77 & China on Response Measures.

Alba will address climate change considerations in their Company sustainability strategy which will be point of focus in 2018.

### Sustainable Development Goals

Alba believes that by embedding the United Nation's Sustainable Development Goals (SDGs) into its business operations, the Company will have a strong platform to continue its journey of making a positive impact on society. In particular, Sustainable Development Goal 12: Responsible Consumption and Production resonates with our strategy and we are committed to channelling our strong leadership and advocacy by partnering with our supply chain to address global challenges and make a difference in this area. Our responsibilities - Social, Civic and Environmental, are entrenched in Alba's operations and the Company will always explore ways and means to serve its stakeholders – this is Alba's primary vocation.

In addition, Alba is working with the Supreme Council of Environment (SCE) and the relevant authorities in Bahrain to adopt sustainable practices and promote sustainable procurement practices in order to ensure sustainable consumption and production patterns.

With Alba's Line 6 Expansion Project underway, we are further committed to adopt the international standards of the Equator Principles and International Finance Corporation (IFC). In doing so, we will be developing plans to ensure efficient use of natural resources, achieve environmentally sound management of chemicals and waste through the business cycle as well as reduce emissions to air, water and soil to minimize adverse impacts on human health and environment.

### Cost Optimisation

Project Titan is a cost-optimisation programme which is aimed to reduce the Company's sensitivity towards London Metal Exchange (LME) prices.

This programme is structured to set vigilant measures in order to sustain Alba's competitive position vis-à-vis its peers as well as enhance the reliability of its operations while streamlining its cost structure.

Phase I was launched in 2014 wherein the aim was to streamline the Company's cash-cost by US\$ 150 per metric tonne (mt) by December-end 2015; actual savings stood at US\$ 148/mt at end of 2015.

Phase II of Project Titan was launched in March 2016 with the aim to reduce cash cost by US\$ 100 per mt and step-up its production capacity to 1,000,000 metric tonnes per annum by end of 2017. Project Titan savings realised normalised benefits of US\$ 79/mt against a target of US\$ 100/mt, during the reporting year.

## Principal Risks and Uncertainties

Risks and uncertainties may have a material adverse impact on the Aluminium Bahrain B.S.C. (Alba) business, financial condition and results of operations, and may result in a decline in the trading price and liquidity of our securities.

Alba's systems of governance, internal control and risk management identify and provide responses to key risks. Some of the risks we face include:

- The cyclical nature of the aluminium industry has historically meant that there is significant aluminium price and demand volatility, and a general production overcapacity in the industry. Alba has no control over a number of factors that affect the price of aluminium
- Alba relies on third-party suppliers for certain raw materials, and any disruption in its supply chain or failure to renew these contracts at competitive prices may have an adverse impact on its financial condition, results of operations and future prospects
- Alba's competitive position in the global aluminium industry is highly dependent on continued access to a competitively priced and uninterrupted natural gas supply. An increase in the price of natural gas, or interruption in supply, could have a material adverse effect on our business, financial condition, results of operations and future prospects
- Alba depends on the provision of uninterrupted transportation of raw materials and finished products across significant distances. Interruption of these activities may have a material adverse impact on the Company. Prices for such services (particularly for sea transport) could increase
- Alba has a number of hedging contracts, and has historically experienced significant mark-to-market and realised losses from certain of the Company's derivative positions
- Exposure to foreign currency fluctuations, and
- High level of competition in the Gulf Cooperation Council (GCC) aluminium market

## Our Key Performance Areas

Social Responsibility	Profitable Growth	Global Competitiveness
<ul style="list-style-type: none"> <li>• Safety</li> <li>• Health Care</li> <li>• Environment</li> <li>• Employee Development</li> </ul>	<ul style="list-style-type: none"> <li>• Growth</li> <li>• Sales</li> <li>• Customer Perception</li> <li>• Innovation</li> </ul>	<ul style="list-style-type: none"> <li>• Cost competitiveness</li> <li>• Throughput increase</li> <li>• Quality of Products</li> </ul>

## Opportunities for Growth

Looking forward, Aluminium Bahrain B.S.C. (Alba) intends to grow the business across the world, particularly in the Middle East and North African region, to benefit shareholders by harnessing regional energy advantage, operational excellence, regional talent and growing the local, regional and international customer base. We will continue to expand on our position as a leading smelter in the Gulf region, ranking among the top 10 on a global scale. In doing so, we remain committed to consistently meet and exceed international environmental standards.

The Free Trade Agreement (FTA) between Bahrain and the USA generates opportunities for exports and imports between both countries and attracts foreign direct investment that aims to capitalise on this agreement. For Alba, the FTA benefits the Company by allowing it to expand its global presence in the USA by selling at market prices that are fairly comparable to other exporting countries.

In order to expand our growth opportunities, Memorandums of Understanding (MoU) were signed with:

- International Bechtel Co. (Bechtel) to explore further opportunities of growth for the Line 6 Expansion Project
- General Electric (GE) wherein GE will initiate a technical and commercial feasibility study to implement a fourth Combined Cycle Gas Turbine (GT) block using GE 9HA technology in Alba's Power Station (PS) 5. This will strengthen Alba's position as an environmentally responsible smelter.

Partnering with organisations that are at the forefront of sustainability focused technological advancement and are growth leaders will ensure the success of Alba's operations into the future.

### Line 6 Expansion Project

Alba's Line 6 Expansion Project is one of the largest brownfield developments in the Gulf Cooperation Council (GCC) region. Expected to begin production on Jan 1, 2019, the project will boost the smelter's per-annum production by 540,000 metric tonnes, bringing its total production capacity to 1.5 million metric tonnes per year.

With a CAPEX of approximately US\$3 billion, the Line 6 Expansion Project involves the construction of a sixth Potline utilising Emirates Global Aluminium's (EGA) proprietary DX+ Ultra Technology, a 1,792 MW power station and other industrial services.

The Front End Engineering Design (FEED) study for the project was completed in the first quarter of 2017 while construction site-works started in the second quarter of 2017.

The Line 6 Expansion Project will make Alba the world's largest single-site aluminium smelter and be a significant economic boost for the Kingdom of Bahrain due to the many co-investment opportunities through local and foreign aluminium investments.

### Line 6 Expansion Project - Key Facts

Project Type - Brownfield	
Capacity	540 metric tonnes
Construction Start Date	2017
First Hot Metal	January 1, 2019
Full Production Date	Q2 2019

Line 6 Smelter Specifications	
Pot Technology	DX+ Ultra (440 kA)
Technology Supplier	EGA
Number of Potlines	424
Length	1.35 Km

Power Station Specifications	
Power Plant Output	1,792 MW
Power Source	Natural Gas
Efficiency	54%

#### Safety Milestones (December 31, 2017)

Line 6 Smelter	> 5 million man-hours w/o LTIs
Power Expansion Project	3 million man-hours w/o LTIs

#### Power Station 5 Progress (December 31, 2017)

# of Contractors on site	10
# of Manpower on site	1,800
Overall Progress	<b>47%</b>
Engineering Progress	90%
Procurement Progress	82%
Construction Progress	20%

#### Power Distribution System Progress (December 31, 2017)

# of Contractors on site	10
# of Manpower on site	535
Overall Progress	<b>65%</b>
Engineering Progress	90%
Procurement Progress	100%
Construction Progress	58%

#### Line 6 Smelter Progress (December 31, 2017)

# of Contractors on site	30
# of Manpower on site	4,769
Overall Progress	<b>40%</b>
Engineering Progress	76%
Procurement Progress	82%
Construction Progress	13%

## Governance and Ethics

### Governance

Aluminium Bahrain B.S.C. (Alba) has adopted, and is committed to implementing the Corporate Governance Code of the Kingdom of Bahrain (the Code), and the Corporate Governance Module (the Module) of the Central Bank of Bahrain. Alba seeks, where applicable, to exceed the minimum requirements of the Code and Module, and to implement additional recommendations and guidance of the Code, as well as other international best practice in Corporate Governance.

Some of the key improvements in corporate governance instituted by Alba in recent years include:

#### Corporate Governance Guidelines

Alba operates in line with a set of Board approved 'Corporate Governance Guidelines'. This document is fully aligned with the Corporate Governance Code of the Kingdom of Bahrain.

#### Corporate Governance Report

The Board has presented a comprehensive annual 'Corporate Governance Report' at each Shareholders Meeting since March 2011.

#### Code of Conduct

A Board approved 'Code of Conduct', on par with leading international codes of ethics, sets out required ethical conduct for all employees and representatives of Alba. Compliance with the Code of Conduct is monitored by Alba's Integrity Task Force, which comprises the Chief Internal Auditor, the Chief Administration Officer and the Legal Manager, and reports directly to the Board Audit Committee.

#### Evaluation and Assessment of the Board and its Committees

The Board and its three standing sub-committees, the Board Audit Committee, the Nominations and Remuneration Committee, and the Board Executive Committee, conduct annual self-evaluations and assessments using questionnaires and a discussion of gaps and areas of improvement. The results of the assessments by the sub-committees are reported to the Board.

#### Directors' Orientation/ Handbook

A Director's handbook consisting of key documents and other content on directors' responsibilities serves as a reference guide for incumbent directors and to facilitate orientation of new directors.

#### Directors' Independence

The Board conducts an annual review of directors' independence, applying the classification criteria and guidance from the Central Bank of Bahrain and from the Code.

#### Conflicts of Interest

Policies are in place to prohibit a member of the Board of Directors from voting in any meeting, or participating in any business operation or activity, in which the member has a conflict of interest with the Company.

#### CEO and CFO Certification of Financial Statements

The CEO and CFO produce a memorandum certifying each quarter's financial statements, as well as the year-end financials.

#### Ownership and Trading of Company Shares

Following the Company's dual listing on the Bahrain Bourse and the London Stock Exchange in November 2010, a process was implemented to identify and report Directors' and Executives' ownership and trading of Company shares. Alba has issued policies on Key Persons Dealing and Insider Trading

#### Levels of Authority

In September 2017, the Board approved an updated Levels of Authority document for the Company. The document defines the limits of approvals and decision-making authority designated to specified positions of responsibility within Alba including the Board and Executives.

#### Succession Plans

An annual review of succession plans for executives is now built into the Board agenda.

## Committees

Alba has constituted the following committees:

Committee Name	Membership
Welfare Committee	Labour Union and Human Resource
Bi-weekly Committee	Labour Union and Human Resources
Executive Committee	Labour Union, Human Resources, and Executives (CXO and CEO)
Safety, Health and Environment (SHE) Committee – Sub-committee	Labour Union and SHE Department
Medical Rehab Committee – Sub-committee	Human Resources and Chief Medical Officer

## Ethics and Integrity

A solid system of Corporate Governance requires a foundation of shared ethical values. Our ethical values are enshrined in our Code of Conduct, which sets out expectations for Directors, Management, employees, and our partners, to act with honesty, integrity, fairness and respect. The Code of Conduct has been launched across Aluminium Bahrain B.S.C. (Alba) by the Executive Team through a comprehensive communication and training programme.

Alba's IntegrityLine is a mechanism through which Alba employees, contractors and commercial partners, and other stakeholders and the broader community can report on a confidential basis, any potential breaches of the Code of Conduct, including financial irregularities, fraud, bribery, corruption, conflicts of interest or any other similar matters of concern.

The IntegrityLine is operated by an independent company and is available in multiple languages, 24 hours a day. The system can also be utilised by all stakeholders, including external stakeholders, to raise non-emergency concerns relating to social and environmental impacts, such as traffic management and/or other community-related issues.

Policies, supported by standard operating procedures and guidelines, and aligned with the Code of Conduct and with the Levels of Authority, provide more detailed expectations on behaviours, activities and processes in the areas of:

- Valuing all people
- Safety health and environment
- Good citizenship and social responsibility
- Ethical business
- Information and confidentiality

Alba's Code of Conduct is revised and re-launched every three years through a comprehensive communication, training and certification programme covering all (100%) governance body members and employees. The last revision and re-launch occurred in 2015. At that time, training and communication was offered to all employees of Alba and reached at least 2,600 of the workforce (around 95% of employees at that time). All employees who have joined Alba since then (in 2016 and 2017) have received training on the Code of Conduct as part of their induction process. Training on human rights and anti-corruption is included within the Code of Conduct training.

Following the most recent launch of the Code of Conduct, the code was communicated to 105 (100% of global customers at that time) Alba customers in addition to 2014 Alba suppliers (100% of all active suppliers at that time).

At the kick off of the Line 6 Expansion Project, Alba's Code of Conduct requirements were outlined at the suppliers forum (attended by over 600 prospective suppliers) by Alba's Board Chairman and Chief Internal Auditor & Risk Officer. A Code of Conduct/ IntegrityLine presentation was also given at the kick off conference to the Power Station 5 winning consortium of bidders, and similar presentation given at the kick off conference to the Power Distribution System consortium of winning bidders.

## Ethics and Integrity

A new 2018 revision of the Code of Conduct has been approved by the Alba Board and will be relaunched to all Alba employees beginning in Q1 2018. In addition, training on the Code will continue to be provided to new joiners as part of their induction process. The 2018 Code will also be shared during 2018 with all active customers, and with all active customers and suppliers.

### Anti-Corruption

Although there have not been any cases of corruption in recent years, the risk of corruption is inherent in the industry in which Alba operates. A high level risk assessment of all (100%) operations has been undertaken as part of Alba's 'Enterprise Risk Management' Framework.

The potential risk areas in our industry are assessed as being bribery or corruption relating to linkages to business partners in the setting of prices with customers, and setting of costs for major raw materials; conflicts of interest; the exchange of inappropriate gifts; kickbacks in the awarding of engineering and service contracts; and facilitation payments by contractors in obtaining permits.

Staff exposed to a higher risk are mainly in Marketing (Head Office, as well as the regional offices in US, Switzerland and Hong Kong), Supply Chain, Procurement, Finance, Projects and Executive Management, while other management level staff are exposed to limited risk.

The vast number of employees (those with no authority to transact) are exposed to no risk/a very low level of risk. Geographically, commercial partners of Alba in countries that have poorer scores on Transparency International's corruption index pose the highest risk (e.g. China and India), however Alba's dealings with companies in these countries is limited.

Activities involving bribery, corruption, money laundering, payment of secret commissions, and the exercise of improper influence are strictly prohibited under our Code of Conduct. We have established an Integrity Programme which is managed by an Integrity Task Force (ITF), consisting of the Chief Internal Auditor, the Chief Administration Officer, and the Legal Manager, with clear objectives and responsibilities, one of which is to review (under the oversight of the Board Audit Committee), fraud, bribery or corruption cases, with updates provided to the Board Audit Committee.

Other mechanisms to manage the risk of corruption include:

- Improving procedures, monitoring and transparency over product prices/premiums. The Alba Board provides management with minimum premium levels for various customer groups, and contracts meeting certain criteria cannot be executed without Board approval. Authority to set and change individual prices and contract terms are set out in the Level of Authority. Management have established processes to optimise premium levels, and to monitor netback (profitability) by customer, and by product which further reduces the risk of suboptimal or non-market driven prices.

- Improving procedures, monitoring and transparency over major raw material costs, and major contracts through the establishment of a tender board, and revised tender policy, as well as a revised Direct Materials Sourcing policy, and revised Levels of Authority. A multi-sourcing strategy for major raw materials has been implemented to promote greater transparency which will more easily highlight and flag noncompetitive transactions.

- New employees are requested to complete a detailed form setting out all potential conflicts of interest, and they are required to notify management of any subsequent changes. Further conflict of interest certifications for existing employees are done periodically. Board members also have to certify any conflicts of interest annually, or as they arise. Criminal record checks are done as part of the employee recruiting process.

In 2017, there was one incident where an employee failed to disclose a conflict of interest. There was no evidence of bribery, but the employee was dismissed for failing to disclose the conflict as required by Company policy. There were no incidents in 2017 of corruption where contracts with business partners were terminated. In the case of the above-mentioned conflict of interest, a tender that had been awarded (but not yet contracted), was re-tendered as a precautionary measure to ensure transparency, once the conflict was identified.

There were no public legal cases regarding corruption brought against the organisation or its employees during the reporting period.



### Anti-Competitive Behaviour

A high level risk assessment has been done of this area as part of Alba's 'Enterprise Risk Management' Framework. The risk in the industry is related to collusion with competitors in the setting of prices for customers, or collusion in allocating customers amongst producers. This risk is limited as Alba's products are global commodities, and prices charged to customers are linked to prevailing global industry indices, such as the London Metal Exchange (LME).

Premiums or discounts to individual customers follow a rigorous review and approval process, set out in Alba's Levels of Authority document, and in Marketing department policies and procedures, and typically require review and approval by the Board of Directors.

Our Code of Conduct clearly states that employees dealing with imports and exports should ensure that practices are compliant with the regulations of the relevant countries, and with applicable international trade controls. Employees dealing with customers should ensure that Alba's practices do not abuse a dominant market position, and are compliant with competition laws in applicable countries.

Employees, business partners and other stakeholders can use the IntegrityLine to raise any concerns about unethical business practices, including anti-competitive behaviour or violations of anti-trust regulations.

There were no legal actions pending nor completed during the reporting period.

Alba's full 2017 Corporate Governance Statement is available at:

<http://www.Albasmelter.com/IR/CorporateGovernance/Documents/Corporate%20Governance%20Report/Corporate%20Governance%20Report.pdf>

Alba's Code of Conduct is available at:

<http://www.Albasmelter.com/IR/CorporateGovernance/Documents/AlbaCodeofconduct.pdf>

### Board Structure

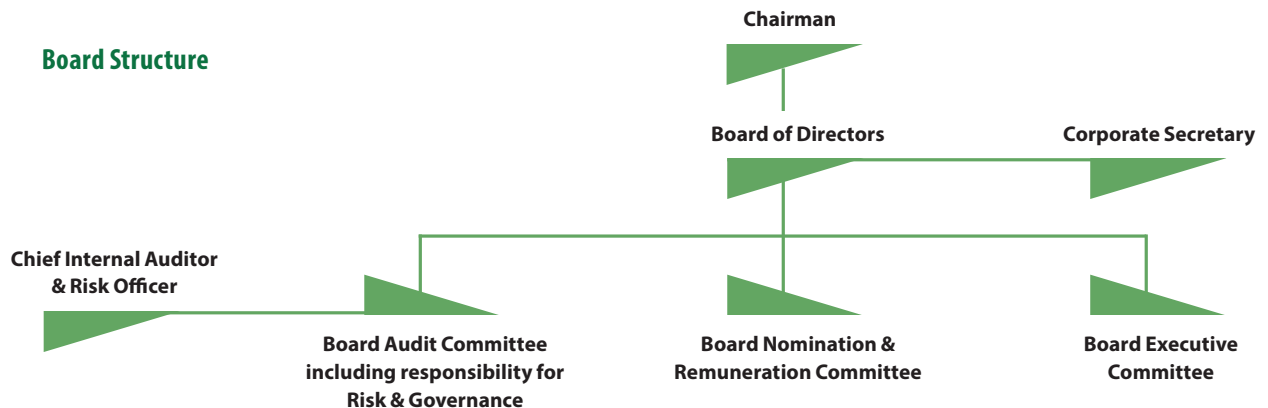

### Organisational Structure

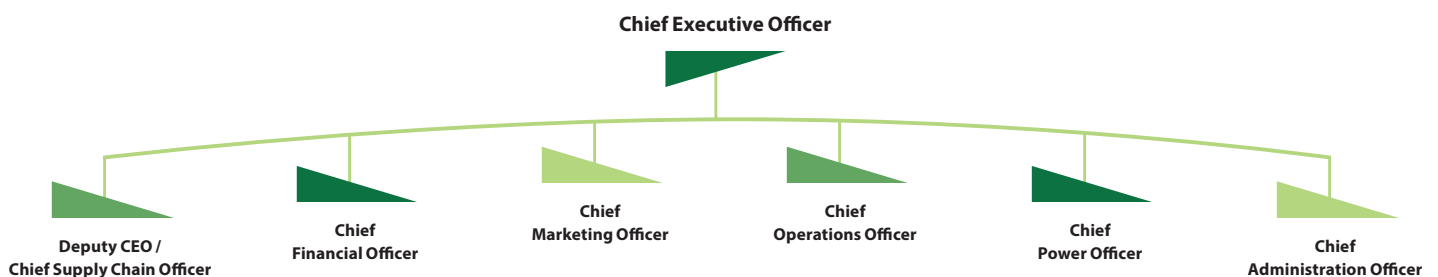

## Environmental, Social and Economic Compliance

Aluminium Bahrain B.S.C. (Alba) complies with all Bahrain Regulations that address environmental, social and economic impacts. As a result of the significant commercial loan received for the Line 6 Expansion Project, Alba is now also bound to comply with the World Bank Organisation (WBO) reporting requirements and International Finance Committee (IFC) Performance Standards on Environmental and Social Sustainability to fulfil lender requirements. As a result of this, Alba will progressively upgrade its policies and procedures that address key impact areas.

In 2017, Alba had no significant cases of non-compliances with environmental, social or economic laws and regulations.

During 2017, Alba was not issued with any fines for environmental breaches. However, during the power outage incident in April 2017 that resulted in a temporary loss of power in all five Reduction Lines for approximately three hours, some exceedance in emissions were recorded as a result of power restoration after the incident.

As a result, the company was required to notify the Supreme Council of Environment (SCE) as the effluent discharge levels in the wastewater outfall exceeded the nominated thresholds during the Line 5 Recovery. Whilst the Line 5 matter has since been resolved, the company is in discussions with the Government to upgrade the effluent pipeline that leaves the site. With the project approved by Alba, the pipeline upgrade project will start once the final routes of the pipeline are agreed amongst the concerned parties.

In the rare event that a potential or actual non-compliance occurs, Alba takes proactive measures to ensure the issue is managed appropriately as per the SCE regulations.

The WBO reporting requirements are available at: [http://www.ifc.org/wps/wcm/connect/Topics\\_Ext\\_Content/IFC\\_External\\_Corporate\\_Site/Sustainability-At-IFC/Policies-Standards/Performance-Standards](http://www.ifc.org/wps/wcm/connect/Topics_Ext_Content/IFC_External_Corporate_Site/Sustainability-At-IFC/Policies-Standards/Performance-Standards).

The IFC Performance Standards on Environmental and Social Sustainability are available at: <http://www.ifc.org/performancestandards>.



## Our Supply Chain

### Sustainable Procurement

As one of the world's leading smelters, Aluminium Bahrain B.S.C. (Alba) plays a key role in engaging local Bahraini suppliers within its operations. Alba's sourcing strategy particularly focuses on a diverse vendor base and aims to boost local manufacturing and supply bases. This ensures Alba's smooth, consistent and reliable supply chain and further improves on operational efficiency and underlines Alba's commitment to economic development and enhancing the business environment of the Kingdom of Bahrain. In 2017, Alba involved nearly 1,550 local firms in dealings reaching almost BD 100 million.

In 2017, Alba's commitment to purchasing from local suppliers topped 56% through purchase orders and agreements (local suppliers refer to Bahrain-based companies which are registered with Alba and/or one-time vendors; this also includes Bahrain-based subsidiaries/extension offices for some of the international companies). Our various supplier engagement programmes and initiatives ensure that our suppliers are our partners in business and success.

Periodic vendor development, sourcing and performance monitoring enables us to strengthen our core business while offering a platform for prospective businesses to thrive. These initiatives include:

- Engagement through safety initiatives and discussion on site or at supplier's premises through bilateral meetings
- Encouraging local manufacturers by providing a platform to develop their product range and by offering assistance in doing so. This directly elevates our reliance on local supplier bases, offering them business boosts, more jobs creation and boost to national economy
- Long term supply engagements using various procurement techniques
- Regular updates on Alba's safety goals, achievements, business developments, cost reduction programmes through direct involvement or through mass communications

Alba's robust vendor pre-qualification policies and procedures are the guiding principles in the development of our strong supply chain.

### Supplier Environmental and Social Assessment

Alba deals with a large number of suppliers locally and internationally. Environmental and social compliance with international standards is essential for our efficiency and compliance purposes. Alba regularly screens its existing major suppliers through its vendor audit programme.

Each year we review the Chemicals & Waste Management Compliance Report of Industries in co-ordination with the Safety, Health and Environment (SHE) department.

We continue to meet Supreme Council of Environment (SCE) regulations while engaging with local vendors, and, in co-ordination with the SHE department, we verify and obtain the necessary permissions to satisfy our environmental commitment during the purchase of goods. Existing or prospective vendors are verified and are required to meet the necessary import, recycle, export and waste management certifications. In FY 2017, over 200 new vendors were pre-qualified on to Alba's approved vendors list after scrutiny on their socio-economic performance. Vendor's environmental performance remains an important criteria, especially for medium to large manufacturing units and depends on the vendor engagement plan.

In FY 2017 alone, Alba screened over 1200 applications from prospective bidders for their social commitments.

Alba's vendor registration policy clearly outlines the needs for the transparency of the vendor's environmental and social performance criteria. Our procurement, human resources and safety health and environment departments are heavily engaged with the monitoring of environmental and social impact and our systems are continually being upgraded to monitor and comply with local and international regulations through an ongoing Request for Disposal (RFD) process.

Alba's vendor general guidelines, in addition to the vendor registration policy is available at: <http://www.albasmelter.com/Procurement/Pages/default.aspx>



Aluminium Bahrain

Batch No.

7827439



Sales Order

0004065057

Location

Cast Drop Number Pcs

534131/1

44

ALLOY	4543.01	UNIT	IN
LENGTH	0	NET	0.000000
SIZE	0	TARE	0.000000
THICKNESS	0	GROSS	0.000000
DATE Time	29/01/2017 02:57		



www.albasmelts.com

MADE IN BAHRAIN

## Our Responsibility for the Environment

Producing high quality products that should never be at the cost of the environment is one of the Company's guiding policies. Aluminium Bahrain B.S.C. (Alba) has always maintained a high track record of quality of the environment by following and implementing international standards. This has resulted in a reduction of our impact on the environment. We have made substantial investments that have enhanced environmental sustainability, as well as aided the preservation of a healthy environment for generations to come.

Alba is progressing a wide variety of initiatives that are based on the precautionary principle which is promoted by the United Nations Framework Convention on Climate Change (UNFCCC) to which the Kingdom of Bahrain has publicly stated its commitment. The essence of the precautionary approach is to make decisions to proactively avoid environmental impacts even when there is limited evidence to confirm that alternative actions would cause such impacts.

For example, Alba's energy reduction initiatives are targeted to reduce costs and environmental impacts, such as the impacts of climate change caused by the release of greenhouse gases.

In 2017, Alba set the benchmark for sustainable power generation with the successful installation of the first H-class General Electric (GE) 9HA Gas Turbine (GT) at its Power Station (PS) 5. We have become the first aluminium smelter in the world to use the largest and most efficient gas turbine produced by GE.

Alba's entire plant operates to the Environmental Management System standard ISO 14001:2004. In addition, the Casthouses and Calciner plant are also operating to the ISO 9001 Quality Management System (QMS).

It is worthy to note that Alba was the first major manufacturing Company, under the category of heavy metal industries in Bahrain to receive this certification - the QMS was upgraded to the 2008 version of the ISO 9001 Standard in June 2009.



## The Aluminium Manufacturing Process

Aluminium metal is made of alumina which is composed of aluminium and oxygen. During the smelting process, aluminium and oxygen are separated to produce aluminium metal. To produce one tonne of aluminium, about two tonnes of alumina is required. Electrical energy is used in the smelting process to separate the aluminium metal from the oxygen. This is done in large steel, carbon-lined furnaces called reduction cells. When alumina is fed into these cells, it is dissolved in molten cryolite. Electricity is introduced into each cell via carbon blocks called anodes that Aluminium Bahrain B.S.C. (Alba) manufactures in-house. All reduction cells in the smelter are connected in a series by an aluminium busbar, which carries electrical current to the cells.

The process is continuous with an electrical current of 100,000 to 320,000 amps flowing from the anode through the alumina and cryolite mixture, to the carbon cell lining, to the anode of the next cell, and so on. The electrical current causes the alumina in this mixture to react with the carbon anode, forming aluminium and carbon dioxide.

In its molten form, the aluminium sinks to the bottom of the reduction cell, while the carbon dioxide and other gaseous by products form at the top of the cell.

Molten aluminium is siphoned from the bottom of the cell by a process called tapping. From the reduction lines, liquid metal is transported to the casthouse where it is poured into mixing furnaces where elements such as silicon, magnesium, copper, iron, titanium or boron are added to meet the customer required alloy specifications.

The prepared aluminium is then cast either in solid mould ingots or direct chill (DC) machines. The metal received from the reduction rooms is then cast into different products. The aluminium that is not cast is supplied in molten form to local industries for their use in manufacturing products.

### Aluminium Smelting Steps

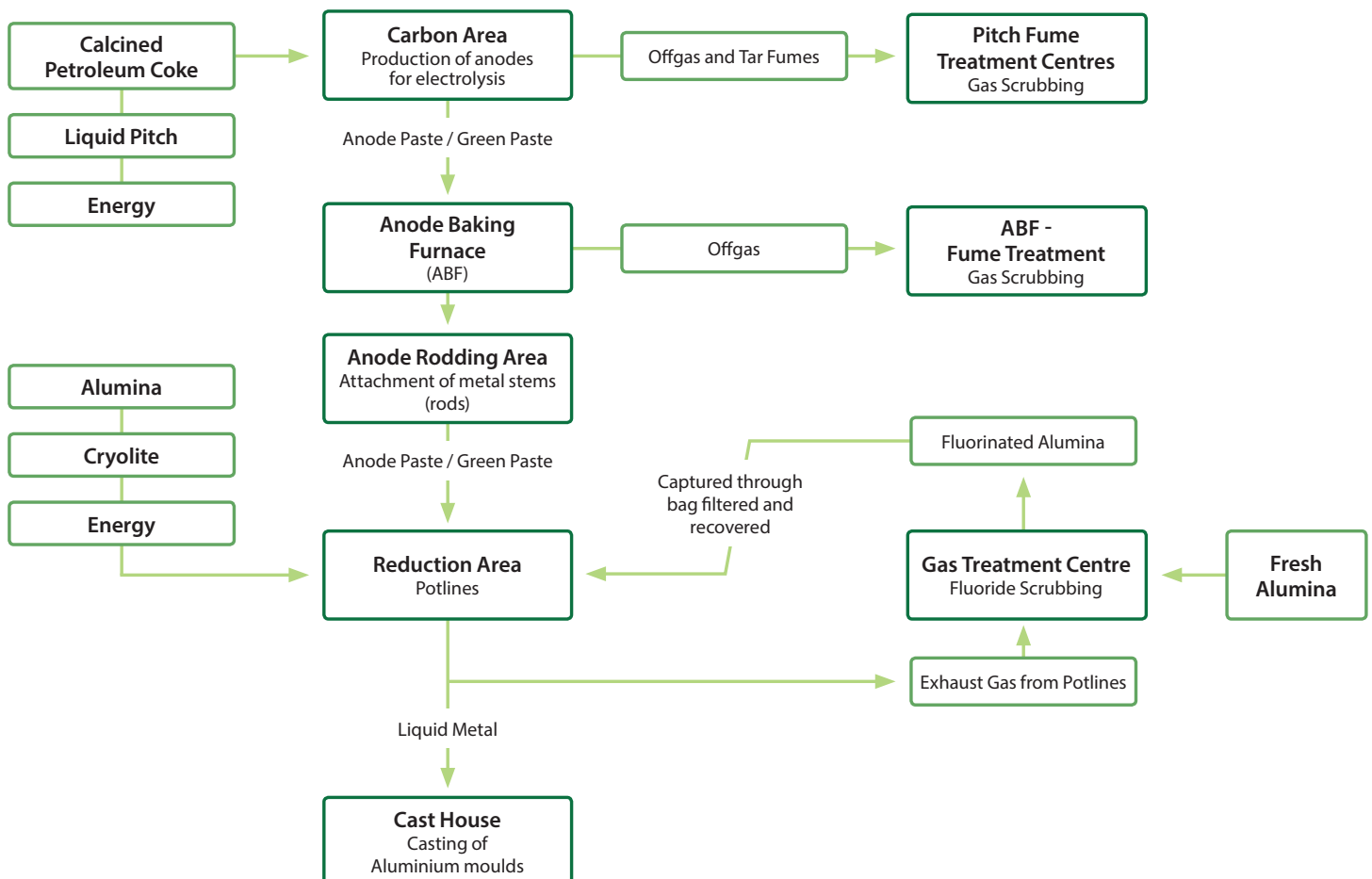

## Materials

Raw materials are an essential part of Aluminium Bahrain B.S.C.'s (Alba) operations and processes. In 2017, Alba sourced its major raw materials from many worldwide locations, including Australia, China all the way to Europe and South America. All materials are prequalified for use, which ensures that they meet Alba's production and environmental compliance requirements. All materials used are subject to material specific internal policies and procedures.

Alba aims to reduce its key raw material consumption equivalent to USD12 million. An action plan was in place in 2017 to reduce the alumina consumption factor from 1.929 (2015 baseline) to 1.915 by year end 2017, which is equivalent to a reduction of 13.500 mt/annum. We achieved this with alumina consumption at 1.914.

Benchmarking is undertaken for all major raw material consumption factors and a plan has been prepared to reduce net carbon consumption, pitch and  $AlF_3$  consumption factors.

Nearly 550,000 mt of baked anodes are required to produce aluminium metal in reduction lines 1 to 5. 75% of carbon anodes are consumed in reduction lines and approximately 25% of spent anode butts are recycled in the carbon plant to minimise consumption of calcined petroleum coke and avoid materials wastage. Around 150,000 mt of anode butts are crushed and recycled back into the green anode making plant to produce new anodes, negating the requirement of an equal amount for anode production.

Recycling is monitored by departments through daily, weekly, monthly and yearly reports and is part of the carbon plant annual production plan. Annually, Alba consumes over 1.9 million tonnes of alumina, 530 thousand tonnes of green petroleum coke, 80 thousand tonnes of liquid pitch and 20,000 mt of aluminum fluoride ( $AlF_3$ ) every year.

### Alba's Self-reliant Supply System

Our strategy of a self-reliant supply system has led to the setting up of the most modern calciner in the world. This has eliminated the need to import calcined coke, the major raw material for the production of carbon anodes used in the aluminium smelting process. The aim of this strategy is to control the quality of the calcined coke by producing it in-house and, thus control the quality of the aluminium we produce.

The quality of calcined coke has a vital role in the resultant quality and performance of anodes. It has a bearing on the cost of metal production and the purity of metal. We have achieved a metal purity of 99.86%. Using 65% of the calcined coke we produce to make anodes for the production of our own primary aluminium has earned us wide recognition across the world for the exceptionally high quality of calcined coke. The remaining calcined coke (35%) is sold to Gulf Cooperation Council (GCC) smelters upon demand. Our calciner is the only completely covered green coke storage facility in the world.

Alba has three computerised carbon plants that produce about 550,000 metric tonnes of anodes every year to ensure a continuous and uninterrupted supply of high quality replacement anodes. Carbon anodes are produced from calcined coke and coal tar pitch. The coke is first crushed and segregated into size fractions then mixed to obtain the required anode quality. This dry mix is preheated then mixed with pitch to bind the coke particles into anode blocks. Liquid pitch is a raw material used to produce anodes where it is used as electrode binder agent. Alba also generates its own power through existing power plant stations.

### Materials Stewardship

As of today, materials stewardship is not formally defined at Alba as the Company adopts a 'lifecycle thinking' approach to make its various stakeholders aware of the benefits of materials stewardship. To that extent, the basic philosophy of materials stewardship flows throughout the organisation through the dissemination of product environmental specifications communicated via marketing materials down the value chain to various stakeholder groups such as customers and shareholders. Practical application of material stewardship is also evident through Alba's efforts in adopting world's best practice technology to reduce energy use and associated emissions.

Much research has been conducted across the globe on the life cycle impacts of aluminium from the production of the raw materials right through the recycling of aluminium products at their end of life. Alba customers are becoming more aware of this research and are looking for ways to both better quantify the impacts and find ways to reduce the impacts in their supply chain. It is therefore in our long-term interest to assist customers on both fronts, and looking forward, we will explore ways to formalise materials stewardship programs throughout our business and practices.



## Key Materials for Aluminium Manufacturing

1

### Alumina

Produced from bauxite ores and extracted from mines throughout various global locations

2

### Green Petroleum Coke / Calcined Coke

- One of the core ingredients used to produce anodes
- Calcined coke produced inhouse by Alba

3

### Liquid Pitch

- A derivative of coal tar
- One of the core ingredients in manufacturing anodes

4

### Aluminium Fluoride

- Solvent
- Critical to managing power consumption



## Consumption Factors

### Net Finished Production

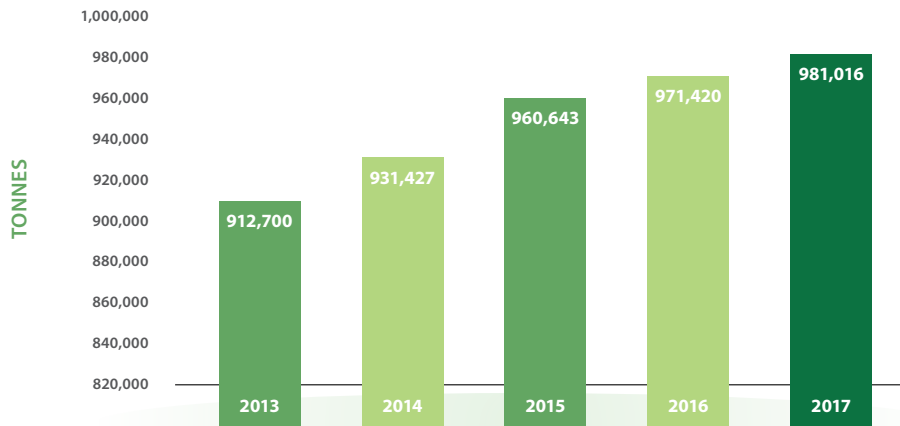

### Alumina Consumption

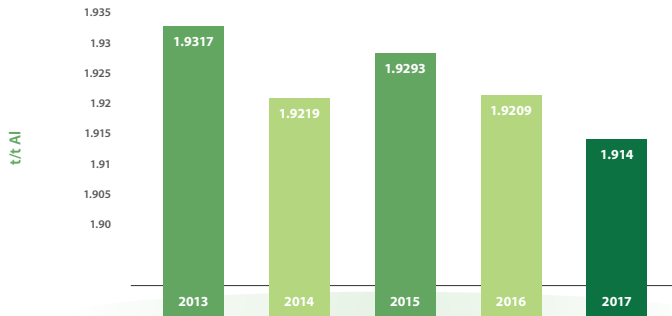

### Natural Gas Consumption

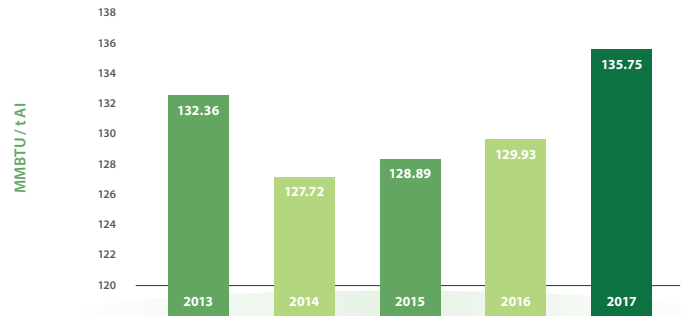

### Aluminium Fluoride Consumption (AlF<sub>3</sub>)

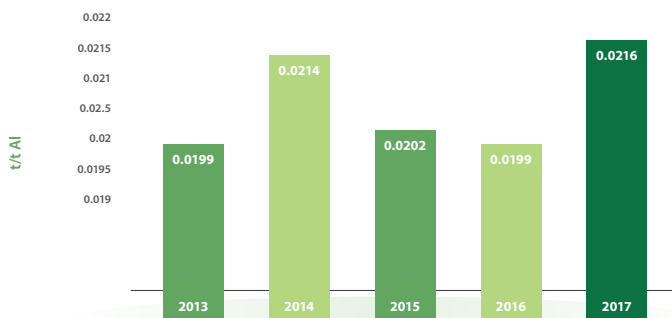

### Green Petroleum Coke Consumption

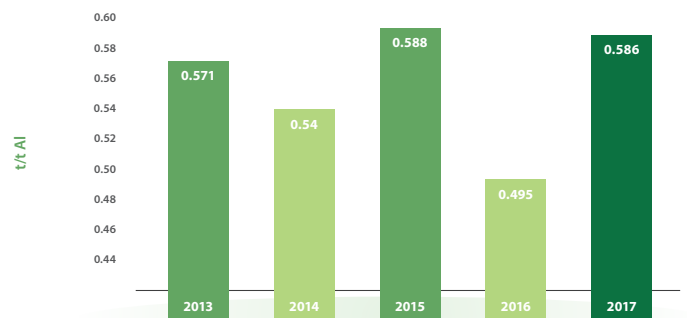

### Calcine Petroleum Coke Consumption

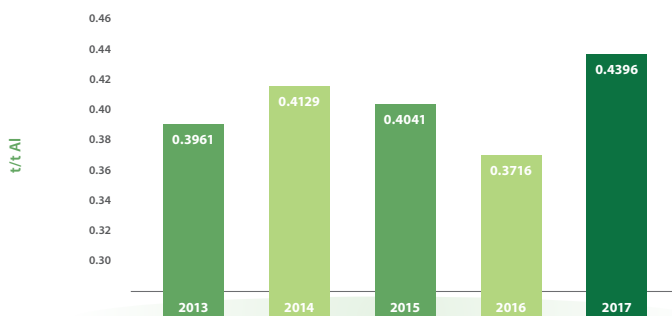

### Liquid Pitch Consumption

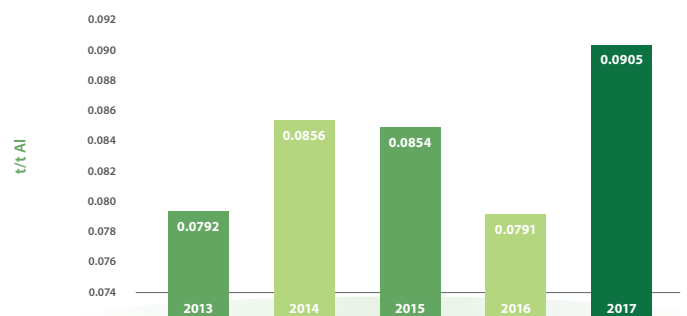

\* Net Carbon Consumption is expressed as Calcine Petroleum Coke and Liquid Pitch consumption separately.

To date, Alba is in the process of installing a butts weighing system in Carbon Plants 1 and 2 in order to report Net Carbon Consumption more accurately.

**Raw materials are delivered to Alba from a number of locations around the world including: Australia, China, Europe and South America.**

The bulk materials, including green petroleum coke, alumina and liquid pitch arrive on ships, which dock at the Alba jetty complex, located about 15km from the main site.

Apart from the material unloading infrastructure, the wharf includes storage facilities and a Calciner plant that converts the green coke to calcined coke that is subsequently combined with liquid pitch to produce the anodes required for aluminium production.

Alba has constructed the world's only completely covered storage for green petroleum coke, which ensures the loss of fugitive dust emissions is minimised, thereby preventing impacts to the marine environment and neighbouring facilities. The protective mechanisms include a large warehouse and coverings over all external conveyor belts.

The Calciner plant uses heat to convert the green petroleum coke. Waste heat is collected from this process and reused at the site to run a desalination plant that converts seawater to potable water for use at the main site.

The desalination plant creates additional potable water for the local community, which is added to the water reticulation network.

In producing one of the world's most pure calcined coke products, Alba completes this with minimal loss of raw materials to the local environment and uses waste heat to produce more than 90% of the main site's water requirements.

Production at the Calciner plant is aligned with Alba's guiding policy that producing high quality products should never be at the cost of the environment.

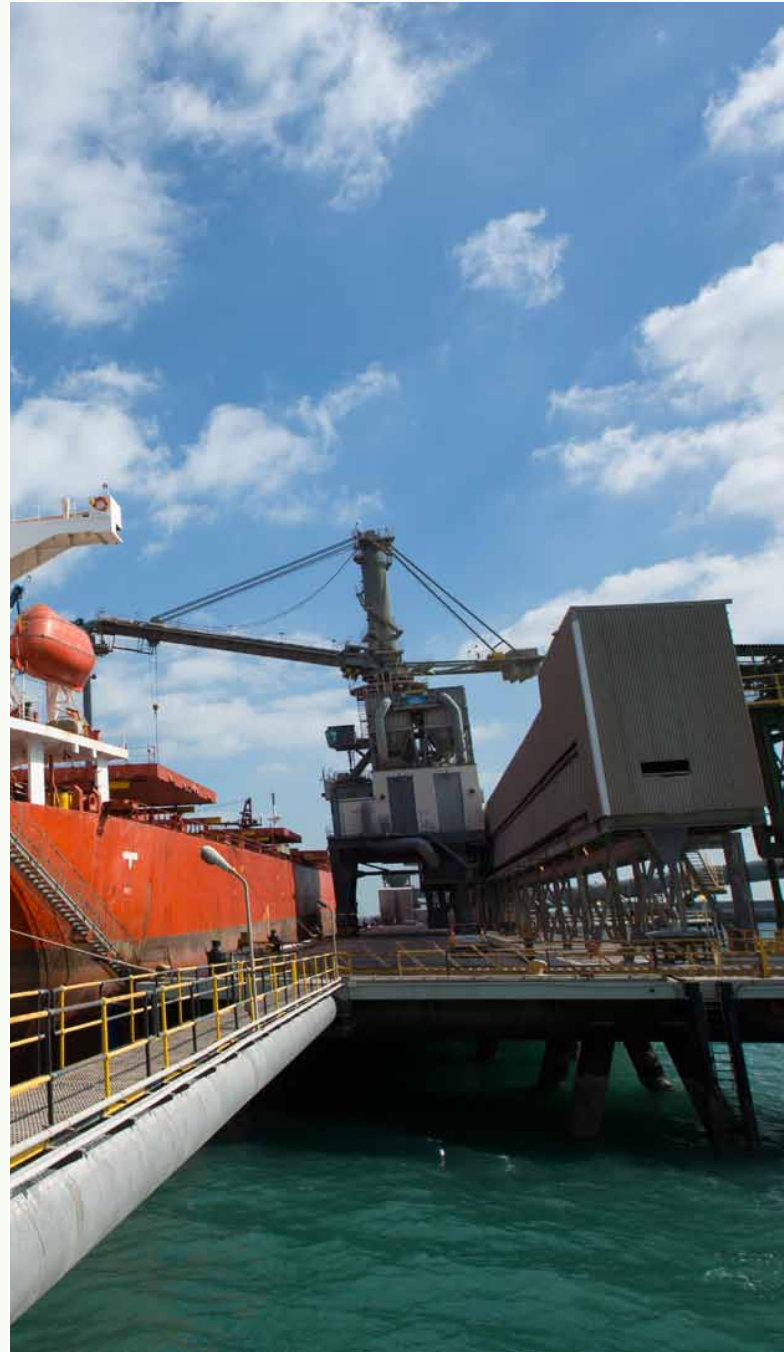

## Calciner Plant: Key Facts

- **World's only completely covered storage for green petroleum coke**
- **Fugitive dust emissions minimised**
- **Creation of potable water for the local community**
- **Waste heat produces more than 90% of water requirements**

## Energy

Aluminium smelters are significant users of electricity and a dependable and sustainable source of electricity is an essential requirement. Aluminium Bahrain B.S.C. (Alba) potlines consume approximately 1,650 MWh, with approximately 1,547 MWh used for hot metal production alone.

We are energy independent since we produce our own power without requiring government supplies or any private company to fulfil our energy needs. We have our own power maintenance, operations and project teams to manage all power requirements. While we generate the required power necessary for running one of the leading aluminium production plants in the world, we make a concerted effort to minimise pollution and help conserve Bahrain's natural gas resources.

The aluminium smelting process is highly power intensive due to the electrolysis process involved. Alba is able to support and ensure self-sufficiency in meeting our extensive energy requirements. This is accomplished through our own dedicated natural gas power plant with its four power stations boasting a total power generating capacity of 2,249 MW ISO. This is equivalent to the average power consumed in the Kingdom of Bahrain as a whole.

While Alba's power consumption surpasses the Kingdom of Bahrain's total power consumption; our generated power exceeds power generated by the local grid. The power plant's present efficiency is 41.45%.

Alba's power stations are equipped with state-of-the-art automatic control systems to operate the plants most efficiently, while maintaining the necessary spinning reserves.

We also have an extensive power distribution network for supplying secure power to all areas within Alba as well as our own Reverse Osmosis plants to cater to Alba's complete potable and industrial quality water requirements.

In our efforts to optimise natural gas consumption for power generation, we utilise the waste heat generated in the gas turbines in the form of exhaust gases. The heat from the exhaust gases is used to generate steam in boilers for producing additional electricity through the use of steam turbines. This combined cycle technology is very efficient and used extensively throughout the world. Power station efficiency is monitored on a daily basis, and reports are prepared monthly.

### Energy Reduction Initiatives

To conserve energy consumption, in addition to various operational initiatives undertaken by plants management teams, energy reduction initiatives were taken with regards to air conditioning (AC) and lighting inside buildings. Controlling AC consumption has the largest impact on the auxiliary overall energy consumption.

AC temperature settings were changed to not lower than 24 degrees Celsius, and timers were installed to change the temperature to 28 degrees Celsius after working hours. Alba also converted all light bulbs to the latest LED technology available in the market, installed sensors to automatically switch off lights when not needed, and adjusted lighting intensity to the international standards of LUX for each function.

These initiatives began in January 2016, and energy consumption in these areas were reduced from 20MW to 12.8MW, representing a 36% reduction.

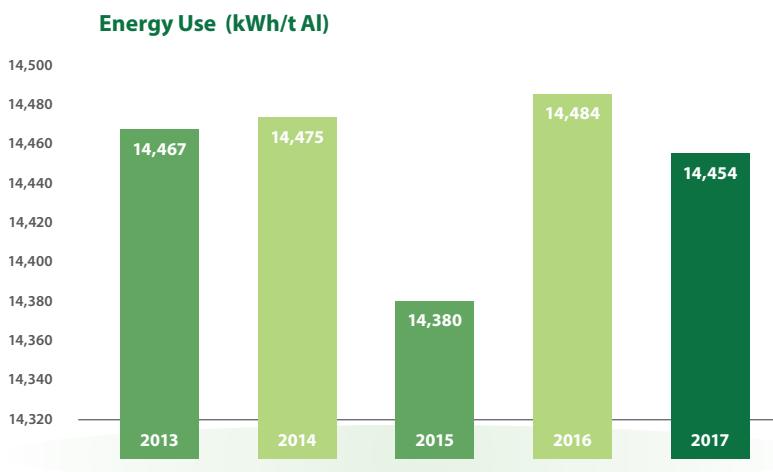



## Water

Aluminium Bahrain B.S.C.'s (Alba) smelting process has a relatively small water footprint and, under normal operation, water requirements are supplied by pipeline from the calciner located at the Alba Marine Terminal.

The energy we use in the aluminium production process is simultaneously employed in the water desalination process. The seawater desalination plant conforms to the World Health Organisation (WHO) and Gulf Standards and the desalinated water is used in the cooling process. It utilises waste heat from the calcining process to generate steam for the production and supply of 41,000 cubic metres per day of potable water to Alba and to the public water distribution networks. Water is also used for cooling and is further purified to create boiler feed water.

The steam that results from this process is then used to generate additional power that helps in saving valuable natural gas energy. This results in Alba producing enormous amounts of potable water that is contributed to Bahrain's Electricity & Water Authority for general consumption in the Kingdom. New water storage tanks will be constructed as part of the Line 6 Expansion Project and will store potable water from the calciner to provide a reserve supply when the calciner is shut down for maintenance.

Alba water plants run at an efficiency of 70% and waste water discharge limits are within the limits as per Ministry of Environment standards and international standards. Ground water usage is monitored and reported on a monthly basis.

Alba's objective is to reuse, recycle and reduce waste water wherever possible. No water is wasted as we utilise the surplus for a variety of uses in and around the plant. 90% of waste water is re-used (the process waste water, which meets irrigation water standards as per Bahrain Supreme Council of Environment (SCE) guidelines, is reused for the irrigation network) and 5% of water is recycled (the treated sewage water. For the remaining 5%, the process waste water is discharged to the Gulf Sea.

One of the prominent uses of this excess water is to irrigate the more than 130,000 square metres of Alba's onsite Her Royal Highness Princess Sabeeka Oasis where more than 15,000 trees, flowers, vegetables and shrubs can be found along with an artificial lagoon where the remainder of treated water is gathered to attract migratory birds and turtles and assorted creatures.

**Total Water Recycled (MI)**

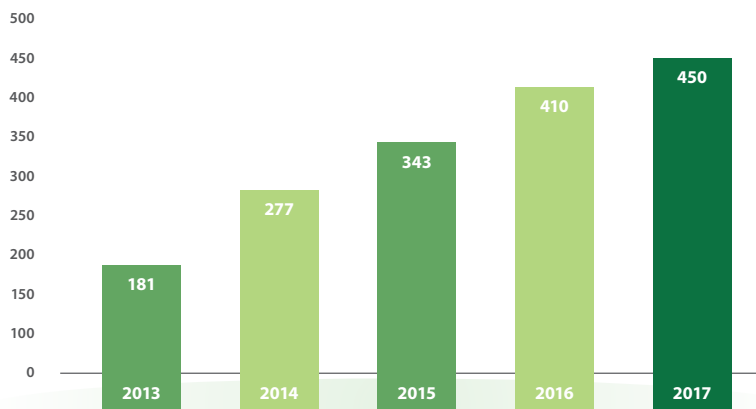



## Emissions

Aluminium Bahrain B.S.C. (Alba) abides by the national legal requirements to reduce emissions impacts produced by the aluminium production process.

The government of Bahrain is a signatory to the Vienna accord and Montreal Protocol and its amendments, and the unified Gulf Cooperation Council (GCC) Ozone Depleting Substances (ODS) regulation. As such, Alba is reporting its ODS and progress of phasing out ODS on a regular basis to the Supreme Council of Environment (SCE). The SCE as regulator is controlling the import of such substances. To date, none of our processes produce ODS.

We have managed recently to completely phase-out the ODS that were previously used in the fire extinguishing media. The only remaining ODS are used as refrigerants in some of our cooling equipment; however, Alba is in the process of phasing-out the remaining ODS and substituting them with ozone friendly substances.

The primary air emissions associated with aluminium production are gaseous and particulate fluoride; sulphur dioxide (SO<sub>2</sub>); carbon dioxide (CO<sub>2</sub>); Nitrous oxides (NO<sub>x</sub>); particulate matter; volatile organic carbons (VOC) and perfluorocarbons.

Fluoride is essential to the electrolysis process and is added to the bath in the form of aluminium fluoride. After most of the fluoride is recovered through scrubbing, some fluoride is released into the atmosphere via the Gas Treatment Centres, the pot room roof vents and the Fume Treatment Centre of the bake furnaces.

The primary source of sulphur is in the green petroleum coke that is used in the manufacture of anodes. Sulphur dioxide is formed as a result of the electrolysis process. The Gas Treatment Centres are the primary SO<sub>2</sub> emission points, in addition to emissions through roof vents and power stations.

The combustion of natural gas and the electrolysis process of anode manufacture are the main sources of CO<sub>2</sub> and emission points include stacks from the remelt/holding furnaces in the casthouse and the Carbon Fume Treatment centres. NO<sub>x</sub> are mainly generated from a range of sources across the smelter where combustion occurs, including the gas turbines in the power stations, holding and melting furnaces and the Anode Baking Furnaces.

Sources of particulate matter are associated either with the combustion process (finer particulates), or mechanically generated dust during raw material handling (alumina and green petroleum coke). Sources include dust collector stacks and dust from pots.

Liquid pitch is the primary source of VOC emissions, which are emitted from the paste plant (green paste and anode production), and in the bake furnace during the anode baking process.

Alba Power Station's present efficiency is 41.45% and NO<sub>x</sub> emission to atmosphere is less than 40ppm.

Greenhouse gas (GHG) emitted during 2017 fall under Scope 1. The components considered in our reporting of GHG emissions are in conformance with the International Aluminium Institute protocol, and the Global Warming Potential (GWP) is extracted from the Intergovernmental Panel for Climate Change (IPCC) 2006. GHG components consists of the following:

- CO<sub>2</sub> generated from the combustion of natural gas at the power stations and other furnaces, such as cast house and carbon
- CH<sub>4</sub> as CO<sub>2</sub> equivalent that is generated from the power plants
- NO<sub>2</sub> as CO<sub>2</sub> equivalent generated from combustion
- CO<sub>2</sub> generated from the manufacturing processes of anodes
- CO<sub>2</sub> generated from the consumption of anodes in the electrolysis process
- PFC as CO<sub>2</sub> equivalent generated from the electrolysis process, and
- CO<sub>2</sub> from other minor contributors such as soda ash addition in pot rooms and packing coke at anode baking kilns.



## Line 6 – Potential Impacts on Emissions

A study commissioned by Alba found that the Line 6 project would generate an increase in stack and potline emissions of 1.3%, and a decrease in power station emissions of 6.5%. The revisions to the Line 6 Expansion Project would thereby give rise to a net reduction in NO<sub>x</sub> emissions, and minor increases in other pollutants releases. Total Hydrogen Fluoride (HF) emissions will increase but roof vent emission concentrations will be expected to remain well below the International Finance Corporation (IFC) Project Standard.

CO<sub>2</sub> emissions will not rise to a significant degree in the context of large energy utilisation and associated CO<sub>2</sub> releases. Changes to GHG emissions will be negligible. The project will exceed the International Finance Corporation (IFC) threshold of 25,000 tonnes of CO<sub>2</sub>e per year. The Equator Principles III require that any project with annual emissions of GHGs in excess of 100,000 tonnes should report its GHG emissions publicly on an annual basis which Alba will be required to undertake.

### Greenhouse Gas Emissions

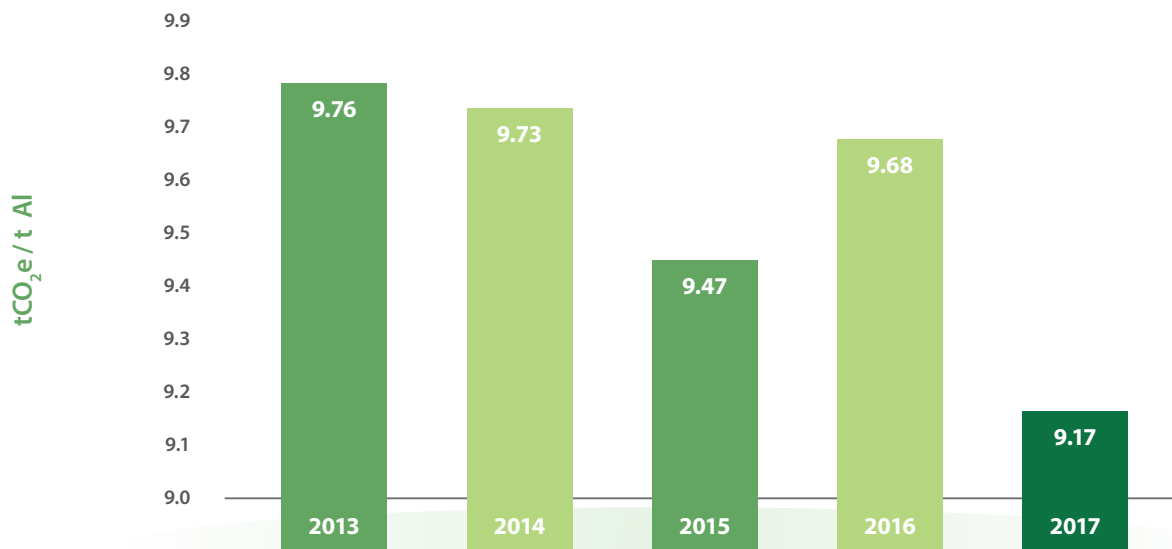

### Emissions Intensity

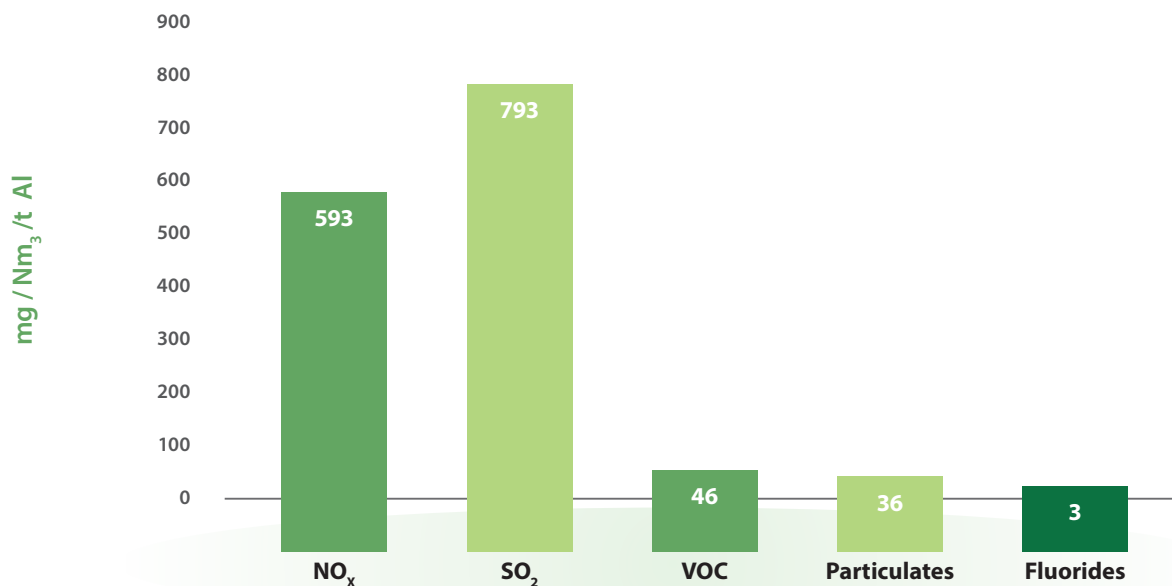

## Effluents and Waste

The major sources of wastewater from an aluminium smelter are the various cooling towers for compressors, casthouses, and other systems across the plant. Due to the nature of the cooling systems, there is a build up of dissolved solids in the cooling water. Clean 'make-up' water is added, and water that is high in dissolved salts is discharged (blown down). Wastewater is also generated from boiler blowdown in the power stations, and additional streams may include wash water and oily water.

These blow downs are the major waste water streams that Aluminium Bahrain B.S.C. (Alba) will manage through its 'Zero Discharge' philosophy. A variety of solid and liquid wastes are generated during smelter operations. Solid wastes include dust, carbon waste, dross, refractory waste, spent pot lining (SPL) and general waste. Spent pot linings are the most significant in terms of quantity and potential for hazard. The risk of cyanide and fluoride leaching requires the spent pot linings to be carefully managed and safely disposed of. Liquid wastes include sewage sludges and oils.

Alba proposed an objective, Zero Liquid Disposal (ZLD) Project (Phase 1 in 2015 and Phase 2 in 2017), to eliminate waste water discharge to the sea and reuse it within the plant.

Taking into account the aluminium industry's impact on the environment, Alba is committed to minimising its impact by monitoring and reducing its water discharge and waste in general, through recycling and treatment of waste. Alba's policies and procedures that cover effluents and waste, including spills and transportation of hazardous waste have been designed to reflect the requirements of the Supreme Council of Environment (SCE) of Bahrain, include regular reviews and monitoring.

Alba has a marine outfall associated with its smelter site located in Ras Zuwayd Industrial Area. The coastal area around the outfall is not subject to any protected status.

The plant's current waste management activities include: segregation, collection and transport, treatment, recycling, storage and landfill disposal. SPL elements are segregated, stored in covered facilities and recycled as soon as possible.

Consistent with the International Finance Corporations (IFC) Environment, Health and Safety (EHS) guidelines regarding waste management, Alba reviews new waste sources during planning, siting and design activities, which enables identification of expected waste generation, pollution prevention opportunities and necessary treatment, storage and disposal infrastructure.

Alba is planning to reduce its total unrecycled waste by 5.01% on an annual basis over a 5-year period resulting in a 27.6% reduction in total. This plan starts in 2018. There were no significant spills during the reporting year.

### Line 6 – Potential Impacts on Effluents and Waste

The low volume of effluent and its general compliance with discharge standards indicates that effluent discharge from Line 6 is unlikely to significantly impact the marine environment. Whilst the impact of the discharge is classified as minor adverse, the discharge is non-compliant with project standards based on IFC guidance. The effluent discharge will need to be compliant with the project standards from 2019 when the operation of the Line 6 and Power Station 5 commences.

Decommissioning impacts through the disconnection and isolation of services are considered significant, however, can be managed through identification and blocking of drainage routes and by maintaining spill kits on site during the work and training staff in spill response procedures. Removal of hazardous materials has been identified as a potentially significant issue that can be managed through appropriate surveys, planning, use of appropriately trained contractors and management controls. Demolition has also been identified as a potentially significant issue that can be managed through maximisation of recycling.

**Solid Waste to Landfill (tonnes)**

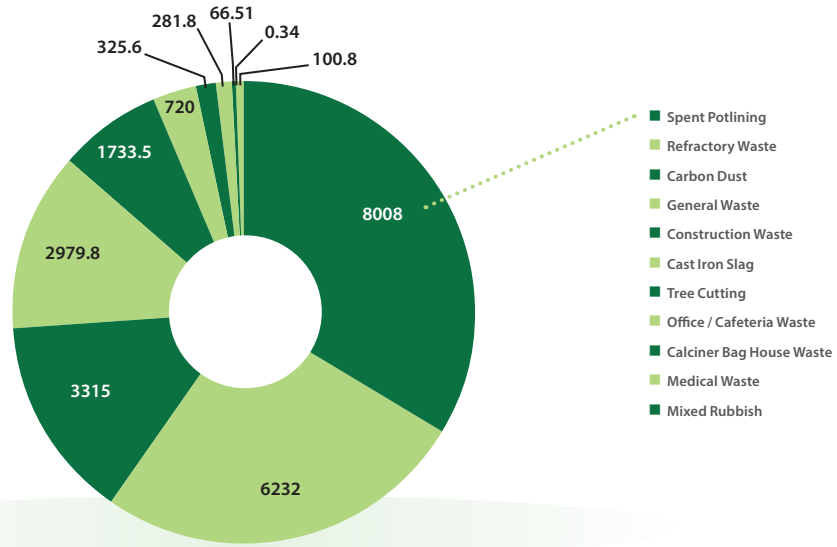

**Solid Waste to Recycling (tonnes)**

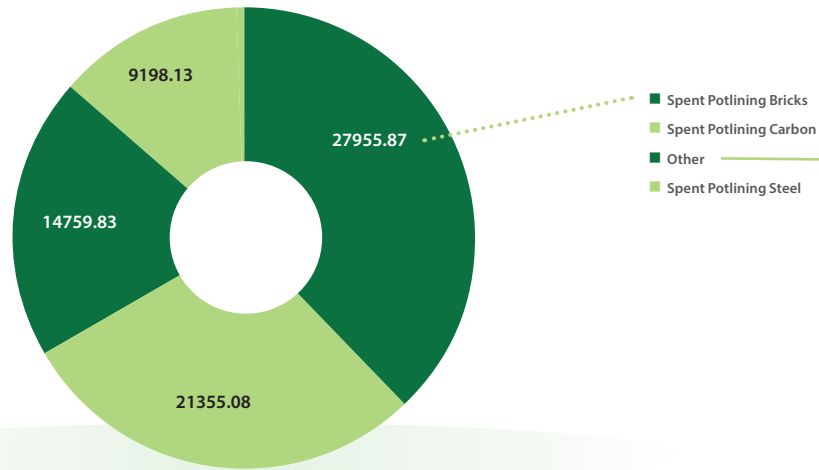

**Solid Waste to Recycling - Other (tonnes)**

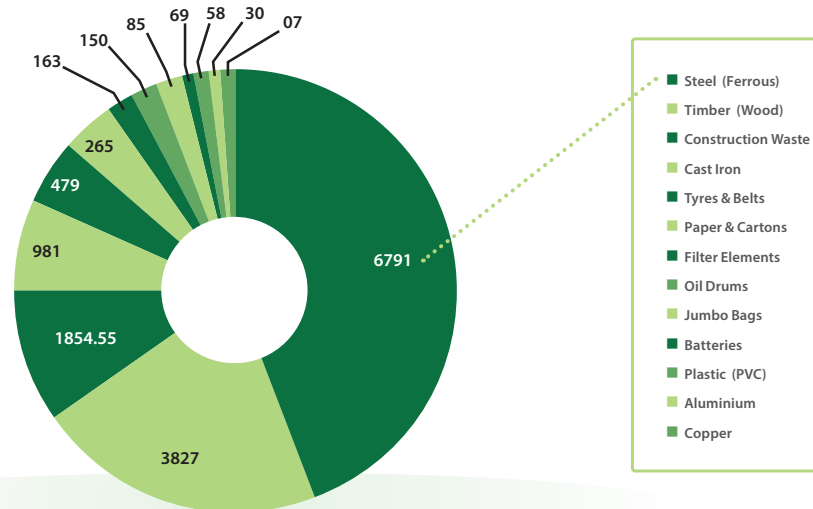

All charts are read from top right, following in a clockwise direction

- Liquid Waste totals 106,042.4 Ml across the business.
- All hazardous waste sent to the hazardous landfill
- Sewage sludge is sent to the governmental sewage treatment plant
- All non-hazardous waste is sent to the non-hazardous landfill
- Liquid hazardous and biomedical waste is sent to an approved incinerator

## Our Responsibility for People

### Vision 2030

Aluminium Bahrain B.S.C. (Alba) remains committed to pursuing the principles enshrined in the Kingdom of Bahrain's Vision 2030, a comprehensive economic vision providing a clear direction for the continued development of the Kingdom's economy bolstered by a shared goal of building a better life for every Bahraini national. Our strategy fits right within Vision 2030's economic and social principles since it runs parallel with the vision of the country and community in which we operate.

Vision 2030 will be underpinned by the National Economic Strategy (NES) detailing strategic initiatives across a range of sectors, which together will deliver the long term aspirations outlined within the vision.

The NES sets the path to transform this vision into reality. It is focused on various initiatives concentrated on education and training, economic, health, and society. It aims to realise His Majesty the King's future economic vision, which places the Bahraini citizen at the heart of growth and development and as the primary beneficiary of prosperity and the opportunities arising from economic and social development.

### Occupational Health and Safety

The operation of large industrial facilities poses the risk of health and safety incidents. Safety is intrinsic to our work culture. It defines how we do our work, and shapes the way we conduct our operations. Safety measures are regularly updated to meet our changing needs. Everyone at Aluminium Bahrain B.S.C. (Alba) is inducted and trained in health and safety practices by OHSAS 18001 certified safety personnel.

The Alba Safety Health and Environment, Security and Fire Department is divided into responsibilities for safety, security and fire, environment and industrial hygiene. The department produces monthly Safety Health and Environment (SHE) statistics which are reported to executive meetings, and annual summary statistics. The health, safety and environmental management systems are certified to OHSAS 18001:2007 and to ISO14001:2004, and externally audited by Bureau Veritas.

The systems are underpinned by Codes of Practice (COP), which apply to all procedures on site. The Job Safety Practice (JSP) within the COP provides a training needs analysis, which in turn informs the individual employee training plan and links to internal, and where applicable, external training provisions.

A comprehensive Industrial Hygiene (IH) management, monitoring and health surveillance programme has been undertaken at Alba. The IH monitoring programme covers all key risks associated with the site and its manufacturing operations, including Hydrogen Fluoride (HF), Coal Tar Pitch Volatiles (CTPV), welding fume, the thermal environment, noise and specific risks to women workers.



As part of Alba’s risk management strategy, planning for emergency scenarios such as fires, metal explosions, electrical incidents, environmental releases, are addressed through the development of Emergency Response Plans and provision of specialist equipment, facilities and training.

Alba’s internal reporting, incident investigation, training and open reporting culture continues to drive its safety philosophy and this approach will be incorporated into the expanded site operations.

Our significant achievements in safety reflect the success of the Company’s long-standing commitment to create a safe working environment and making safety a guiding principle in all areas of work.

Winning prestigious international safety awards like the RoSPA and the British Safety Council for many consecutive years is another testimony to our unrelenting pursuit of occupational safety. We are constantly upgrading safety systems through the active involvement of our Risk Assessment Committee, which examines all potential risk situations in the plant and help to enhance safety on the shop floor.

In 2017, a safety campaign ‘Safety in all Seasons’ was conducted comprising of safety presentations by various managers and department heads.

**Total Recordable Injury Frequency Rate (TRIFR)**



**Lag Indicators**

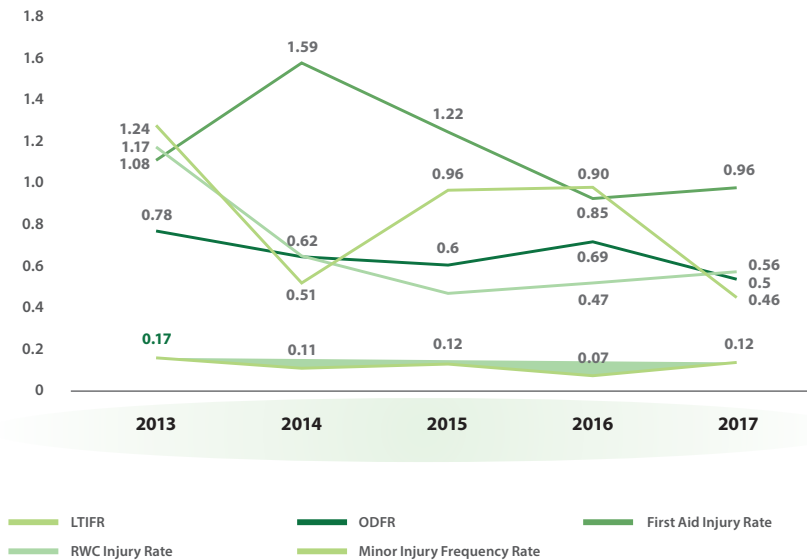

• There were no fatalities in FY2017

## Aluminium Bahrain B.S.C. (Alba), in line with its commitment to higher safety culture, launched its plant-wide safety campaign 'Safety Tomorrowland' in May 2017.

**“Alba takes pride in providing its employees a safe place to work. As we commence line 6 construction, safety will remain our top priority at all times.”**

Shaikh Daij Bin Salman Bin Daij Al Khalifa, Chairman

The campaign was inaugurated by Alba's Chairman of Board of Directors, Shaikh Daij Bin Salman Al Khalifa and Chief Executive Officer Tim Murray in the presence of the Executive Management, Directors and Senior Management as well as employees from different departments.

The Safety Tomorrowland campaign is a key component of Alba CEO Tim Murray's 2017 Company expectations.

Safety Tomorrowland aims to take safety to a high level through the roll-out of various initiatives and campaigns. The campaign provides another step towards Alba's ultimate goal of a zero accident work environment, particularly with construction activities currently underway for the Line 6 Expansion Project.

Key Safety Tomorrowland activities in 2017 included:

- Daily after-Iftar safety visits to shop-floor employees around the plant during the Holy Month of Ramadan. Visits to various operational areas around Alba aimed to increase safety awareness amongst Alba employees and contractors, to keep healthy and hydrated as well as boost their morale especially in the hot summer months.
- Visits to shop floor employees in various areas of Alba plant during the Eid Al-Fitr holidays in June, 2017.
- Inspection visit to one of the Bahraini major equipment contracting companies for Line 6 Expansion Project - Ahmed Mansoor Al Aali (AMA Group). The AMA Group is manufacturing 427 pot shells (each weighing 44 metric tonnes) for Alba's Line 6 Expansion Project. In addition, AMA Group along with its partner ALUCOR Ltd. (Dubai) are fabricating 424 ring bus bars (each weighing 47 metric tonnes). These major smelter components are some of the largest ever manufactured in the aluminium smelting industry in the world. AMA Group adopts the stringent safety procedures that underline Alba's core safety values.

- Launch of a new safety awareness campaign "My Health ... My Responsibility", targeting Line 6 Contractors. The launch was held in partnership with the Ministry of Health under the patronage of the Undersecretary of Bahrain's Ministry of Labour and Social Development, Subah bin Salem Al Doseri.

The tailored campaign aims to improve the contractors' awareness towards safety and health during the summer months especially heat stress and dehydration.

- Visits to shop-floor employees within the plant including Reduction Lines, Power Stations and Casthouse operations during the Eid Al Adha holiday.

- Launch of the new safety campaign 'Safety in all Seasons'.

In addition to these initiatives, Alba celebrated a major safety milestone as its Casthouse successfully achieved 5 million hours without Lost Time Injury (LTI) in November, 2017. A celebration was held on the same day to appreciate the Casthouse employees.

Alba continuously maintains safety awareness campaigns throughout the year, through the weekly Monday safety hours, safety talk prior to each shift, annual or department-led Safety, Health and Environment (SHE)Week, safety reviews and observations, and site visits amongst others.

December 2017 saw another significant safety achievement of 5 million work-hours without Lost Time Injury (LTI) in its Line 6 Smelter (Owner's team and contractors) - further testament of Alba's commitment to a zero-injuries work environment.

**“The launch of the safety tomorrowland campaign is another step towards our ultimate goal of a zero-accident work environment. Alba will continue to focus on awareness and proactive steps in order to prevent all injuries and illnesses.”**

Tim Murray, CEO

## Employment Conditions and Benefits

Employment at Aluminium Bahrain B.S.C. (Alba) is based on the key principles of equal opportunity and the Free Labour Movement which in turn is a core principal of the International Labour Organization (ILO).

In addition to looking after our internal employees, it is intrinsic to us that all contractors and their employees have clear and understandable information regarding their rights under national labour and employment law, including their written statement of rights related to hours of work, wages, overtime, compensation, and benefits upon beginning the working relationship and when any material changes occur.

Outside of our employee base, two types of labour contracts are engaged in the Operations, Maintenance and Services areas at Alba:

1. Hire of Labour: semi-skilled and skilled contract labour are hired through a contractor to work directly under the supervision of Alba and they are paid on a daily or hourly rate. This is done to cover the variable work load jobs and seasonal jobs. 319 Hire of Labour are deployed per day.
2. Job Contract: Contractors undertaking jobs on a turnkey or on assigned work basis and payment is made for the job performed.

There were no significant variations in labour as any additional labour is part of the planned workforce. Seasonal variations such as the summer period and operational and maintenance variations are covered by Contract Labours.

Alba adheres to and is in compliance with all applicable employment laws of the Kingdom of Bahrain, including the Bahrain Labour Law 2012, Bahrain Law No. 19 of 2006 under on the organization of the labour market and Bahrain's Law on Workers Trade Unions promulgated by virtue of Decree Law No. 33 of 2002 as amended by virtue of Law No. 49 of 2006.

Alba offers priority employment to Bahraini nationals, and only recruits expatriates when suitably qualified and experienced Bahrainis are not available. Achieving 84 percent Bahrainisation within the Company is just one example of Alba living up to its commitment to the Kingdom of Bahrain's Economic Vision 2030 – well about the national target of 25% Bahrainisation.

We endeavour to assure national employees of continuous employment as much as possible, and use the most efficient methods of production throughout Alba operations, as true security of employment can only come from competitiveness arising from efficiency.

Innovation provides the springboard for creating a dynamic energy in the work culture and in the value creation involved in aluminium production. It sets the stage for a whole new mindset while undertaking work, fulfilling required tasks, meeting goals and delivering results.

Our employees are encouraged to be innovative through the very popular Good Suggestions Scheme. Here, Alba employees can present innovative ideas that contribute to their work environment and overall safety. Many successful projects have been introduced as a result of this scheme resulting in cost effective solutions.





Alba remains at the forefront of ensuring that employees' benefit from a safe work environment, enabling them to be healthy and productive. At the centre of Alba's occupational health initiatives is the Alba Healthcare Centre, which is regarded as one of the most advanced medical facilities available in any industrial organisation in Bahrain.

The Alba Healthcare Centre provides a comprehensive range of medical services to all Alba employees, as well as emergency services to residents in the neighbouring areas. The centre regularly conducts various campaigns and health awareness lectures targeting the Company's workforce. Alba also provides its employees with medical insurance packages which has been extended to cover employees' families and those who need it for a reasonable fee.

Alba supports numerous community-oriented programmes such as the blood donation initiative which is held twice a year to support the Central Blood Bank at the Salmaniya Medical Centre.

Benefits for Alba permanent employees include:

#### Life Insurance

This is covered by Social Insurance (SIO) Law and as per Bahrain Law. Supervisory and above employees are covered by additional group life Insurance cover

#### Health Care

All employees are covered by Comprehensive Medical Insurance cover

#### Disability and Invalidity Coverage

This is covered by Social Insurance (SIO) Law and as per Bahrain Law. Supervisory and above employees are covered by additional group life Insurance cover

#### Parental Leave

As per Bahrain Labour Law only female employees are entitled to maternity leave and feeding hours

#### Stock Ownership

Alba provides 1000 shares to each permanent employee.

#### Retirement Provisions

- Salary and allowances up to and including last working day
- Payment in lieu of accrued leave
- Payment of 50% of unutilised sick leave at a gross salary, up to a maximum of 189 days
- National employees receive benefits under the Alba Savings and Benefits scheme and an ex gratia payment at the rate of 90 days salaries to be paid
- Expatriate employees receive an indemnity payment as per contract
- Retirement gift

In addition, Alba provides the following benefits\*:

- Free transport for non-supervisory employees and transport allowance for supervisory levels and above
- Free laundry
- Subsidised canteen facility
- Free membership of Alba club with health, fitness and sports facility
- Ramadhan basket
- School bag gift
- Long service award
- Bahrain Women's Day gift to female employees

*\*Benefits are only available to permanent employees*

The Bahraini Labour Law is available at:  
<http://lmra.bh/portal/files/cms/shared/file/labour%20law%202012.pdf>



## Employment Data



Recruitment							
	Expatriate	Male	Female	National	Male	Female	TOTAL
Above 50 years	1	1	-	-	-	-	1
Between 30 - 50	21	21	-	18	17	1	39
Below 30 years	1	-	1	105	104	1	106
<b>Total Recruitment</b>	<b>23</b>	<b>22</b>	<b>1</b>	<b>123</b>	<b>121</b>	<b>2</b>	<b>146</b>

Turnover							
	Expatriate	Male	Female	National	Male	Female	TOTAL
Above 50 years	8	8	-	16	16	-	24
Between 30 - 50	2	2	-	31	29	2	33
Below 30 years	-	-	-	16	15	1	16
<b>Total Recruitment</b>	<b>10</b>	<b>10</b>	<b>0</b>	<b>63</b>	<b>60</b>	<b>3</b>	<b>73</b>

Total number of employee entitled to parental leave (As per Bahrain Labour Law 2012 only female employees)	Total number of employees who took parental leave, returned to work and were still employed after 12 months	Return to work and retention rate
28	28	100%

### Employees by Contract and Gender

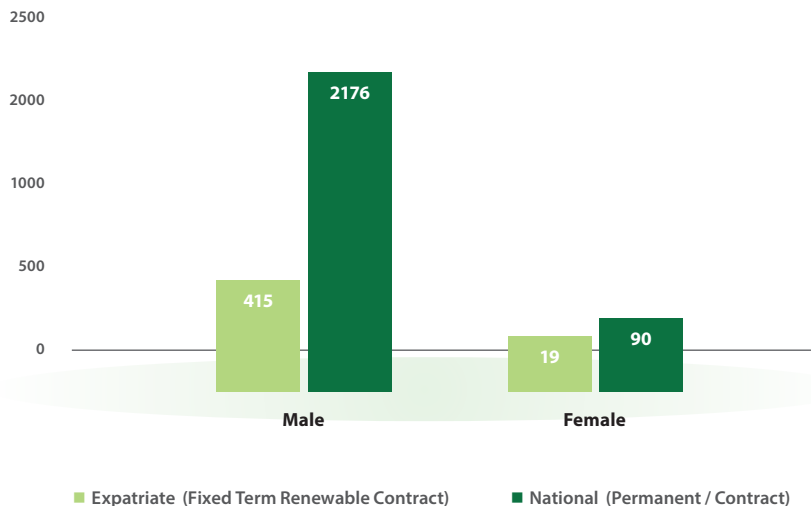



## Human Rights

Being a socially responsible business means that we encompass all stakeholders who can be affected by our organization. Aluminium Bahrain B.S.C. (Alba) considers itself to be 'in the people business' and our key focus will always be on people as they in essence keep the Alba business running.

Alba is fully committed to the principles of the United Nations 'Protect, Respect and Remedy' Framework for Human Rights. These guiding principles are grounded in recognition of:

- (a) Obligations to respect, protect and fulfil human rights and fundamental freedoms - which Alba ensures by having policies, procedures and systems aligned with the Labour Law, the Union Law, Free Labour Movement Regulations and International standards;
- (b) The role of business enterprises as specialised organs of society performing specialised functions, required to comply with all applicable laws and to respect human rights - Alba fulfills this by having Corporate Social Responsibility Initiatives to benefit the society; and
- (c) The need for rights and obligations to be matched to appropriate and effective remedies when breached - Alba achieves this in the framework of prescribed Law by having grievance procedures, Code of Conduct, IntegrityLine, audits and various other mechanisms.

In addition, Alba's Code of Conduct clearly states that 'Alba affirms the Principles contained in the United Nations Charter and in the Universal Declaration of Human Rights'. Therefore, Alba is committed to all the principles contained therein. The same Code of Conduct also sets out Alba's policies safeguarding the areas of respect, non-harassment, fair treatment and equal opportunity; it also sets-out Alba's commitment to the elimination of all forms of forced and compulsory labour and the abolition of child labour abuse.

In totality, Alba business and its growth are based on protecting, respecting and providing remedy to human rights issues.

### Line 6 – Potential Impacts on Employment and the Workforce

The construction phase of the Line 6 Expansion Project will require the employment of a large workforce of up to 15,000 persons. The majority will be expatriate male workers from the Indian sub-continent who will be employed on relatively low wages with accommodation provided in labour camps by their employer.

There have been numerous reports from the Middle East region concerning poor treatment of such migrant workers including: poor health and safety standards, poor accommodation standards and non-payment of wages. Hence these are key issues for the assessment and management of the Line 6 construction phase.

Alba will work strictly under our Code of Conduct and associated Bahraini Labour Laws to ensure working conditions for Line 6 workers during the construction phase.

Personnel who are working for the Line 6 project are managed via contractual agreements between Alba and their contractors. These contractual arrangements govern how contractors ensure the wellbeing of their employees as required by the Bahraini Labour Laws and the International Finance Corporation Performance Standards relating to workers rights and wellbeing. Key documents include a Schedule of Contractor Practices, the Employee Relations Management Plan and the Potline 6 Site Mobilization Procedure.

These obligations form a core part of each contract, and focus on:

- 1) Ensuring the employee is legally able to work within the Kingdom of Bahrain for a specific employer
- 2) Ensuring the employee is provided all the rights of expatriate workers, as outlined in the Labour Laws, and
- 3) Ensuring the employee is inducted by the project, which includes extensive Environmental, Safety and Health (ESH) training and safe site access requirements.

The Line 6 Project ensures that workers accommodation facilities meet all requirements of the government of the Kingdom of Bahrain. The 2017 Supplementary Environmental and Social Impact Assessment has further strengthened key contractor obligations towards their employees in terms of access to information, access to grievance mechanisms and adherence to human resources policies.

Evaluating the effectiveness of the management of workers' rights on the Line 6 project is ensured in a number of ways.

These include:

- 1) Extensive contractor evaluation prior to their acceptance for the project

- 2) Strict adherence to the site mobilisation procedure and the conditions outlined in each Contractors Employee Relations Management Plan (including regular payroll audits), and

- 3) Regular auditing and inspection of contractor facilities, including accommodation facilities and site based worker welfare facilities (such as lunch rooms and sheltered break areas) to ensure these facilities are safe and meet project expectations.

Additionally, the Line 6 project records all contractor grievances in a centralised register to act on them pursuant to the degree of severity of the issue. In 2018, a metrics based performance assessment tool is planned to be implemented by the project to help refine awareness of, and compliance with, core components of International Finance Requirements.

## Training and Education

By supporting staff in enhancing their skills and broadening their scope of knowledge, we are taking steps to maximise our own productivity.

As a leading employer of Bahrainis, we believe that it is only through dedication and an enduring commitment to professional development that both our Company and our country can continue to grow and achieve success.

For over forty years, we have been committed to providing Bahraini nationals with meaningful training opportunities through appropriate training systems that help build successful careers.

By supporting employee career and training, the vision and mission of Alba can be successfully achieved.

Our training programmes have been specifically designed with the business in mind and we also participate and work closely with many national organisations with an aim to provide trainees with the knowledge, skills, tools and technical on-the-job training they need for successful employment.

We invest heavily in the training and development of our employees and contractors, and focus on safety, health and the environment, in addition to providing training on technical aspects, OEM, and management skills.

As a corporate citizen proud of its Bahraini roots, we want to ensure that our company is a unique and excellent place for our employees to work, and in line with this, we remain committed to strengthening our learning culture. We aim to strengthen our reputation as an employer of choice amongst nationals through numerous training initiatives such as the Training Development Programme (TDP), Skill Matrix and higher education in various fields, which enable employees to enhance their potential and become future leaders.

The Skill Matrix Assessment scheme enables a maximum of 600 non-management staff to enter the assessment process each year for promotion. This scheme has ensured regular progression of non-management staff, their development and multi skilling. In 2017, 124 employees completed the skills matrix scheme.

The TDP gives employees the opportunity to take greater responsibilities within the workplace which enables them to be promoted to higher positions by the end of the programme.

Alba works closely with leading universities and educational institutes both nationally and internationally. We work in partnership with projects like inJAz Bahrain and Tamkeen to provide effective training programmes for Bahraini nationals and provide considerable financial and practical support to inspire young Bahrainis to succeed on the global platform.

Each year, Alba targets an average of 115.2 hours (6% of working hours) per employee for training. In 2017, we exceeded this target and reached an average of 131.6 hours of training (6.85% of working hours), with 132 hours average for male employees, and 112 hours average for female employees.

We celebrated the recent appointment in December 2017 as an approved and licensed training provider for the course 'Managing Safely' by the Institution of Occupational Safety and Health (IOSH), UK.

Internal audits are conducted annually to review and amend training policies and procedures.

In addition, an external agency is hired annually to review training and development policies and procedures and provide recommendations, and, monthly monitoring is undertaken by the training department to review training hours and feedback reports on training programmes.

143

Average hours of training

Average Hours of Training - per Department

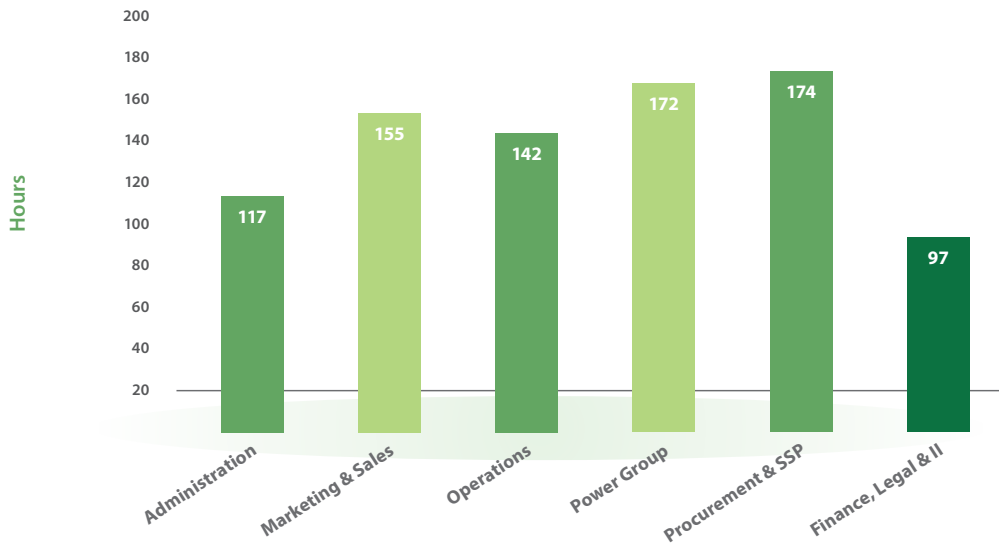

Average Hours of Training - per Employee Category

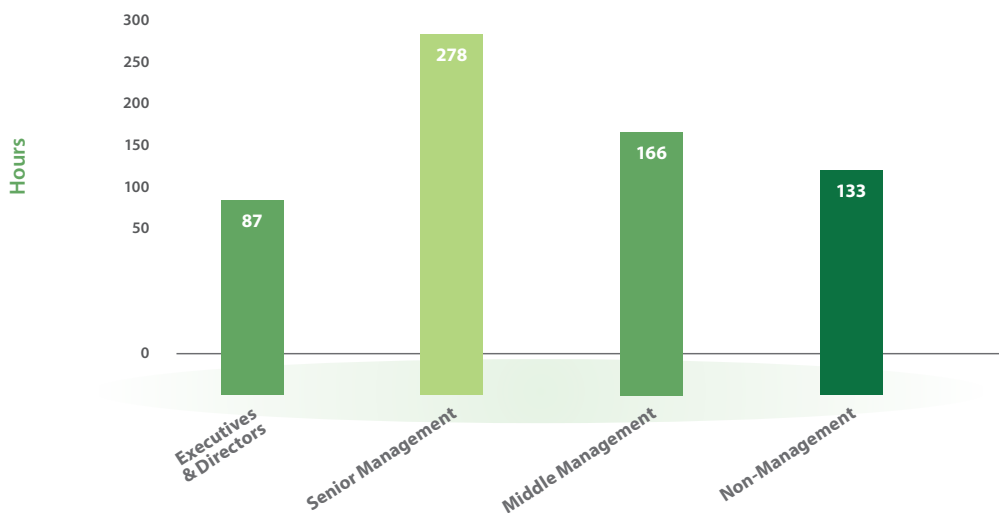

## Labour and Management Relations

We consider our workforce as a valuable asset through which a sound worker-management relationship should be nurtured. In 2002, Aluminium Bahrain B.S.C. (Alba) became one of the first companies in Bahrain to establish an active labour union directly elected by employees. Today, Alba has two of the most active unions in Bahrain - the Alba Labour Union and Alba Trade Union. All employees below manager level are eligible to become members.

The main role of the unions is to represent all employees before Management and other bodies. Their main objective is to improve the social, financial and employment conditions of employees in general and of their respective union members. Management – Union relations facilitated through human resources in the following areas include:

- Safety health and environment
- Employee welfare
- Review and facilitation of employee services
- Employee relations – grievance mechanisms
- Alba community service
- Employee representation

All issues related to these areas are discussed and resolved within the ambit of Alba policies which are in line with Bahrain labour laws.

Apart from maintaining harmonious and constructive relations, the unions have contributed with human resources to:

- Developing human capital
- Promoting safety, health and environmental protection
- Developing the Bahraini society
- Encouraging community service and voluntarism
- Supporting the local community

Both unions are Alba's partners in growth and development of its culture.

Alba follows the Legislative Decree No. 33 with respect to promulgating the Workers Trade Union Law and subsequent amendments and the Bahrain Labour Law 2012 for all industrial relation issues.

The Legislative Decree is available at:  
[http://www.ilo.org/dyn/natlex/natlex4.detail?p\\_lang=en&p\\_isn=77979](http://www.ilo.org/dyn/natlex/natlex4.detail?p_lang=en&p_isn=77979)

The Bahraini Labour Law is available at:  
<http://lmra.bh/portal/files/cms/shared/file/labour%20law%202012.pdf>

## Glossary

---

**AlF<sub>3</sub>**

The chemical symbol for aluminium fluoride. It is an inorganic compound used primarily in the production of aluminium.

**Alloy**

A mixture of minerals made by combining two or more metallic elements, especially to give greater strength or resistance to corrosion.

**Alumina**

The raw material for aluminium production which is also known as aluminium oxide.

**Aluminium**

The most abundant metal in the earth's crust and is obtained mainly from bauxite.

**Amp**

Abbreviation of ampere - the electrical unit of measurement.

**Anode**

The positive electrode of an electrochemical cell.

**Bahrain Bourse**

The Bahrain Stock Exchange.

**Boron**

An element added to aluminium for improving electrical conductivity.

**Busbar**

A system of electrical conductors in a generating or receiving station through which power is concentrated for distribution.

**Calcined Petroleum Coke (CPC)**

A critical ingredient, in the production of aluminium, created by placing high quality raw 'green' petroleum coke into rotary kilns, where it is heated to remove excess moisture, extract all remaining hydrocarbons and modify the crystalline structure of the coke, thus resulting in a denser more electrically conductive product.

**Coke Calcining Plant (Calciner)**

Alba's facility that is responsible for producing calcined petroleum coke from the raw material 'Green Petroleum Coke'.

**Carbon Plant**

A unit within Alba that is responsible for moulding the CPC into anode blocks that are used in the reduction lines.

**Casthouse**

A unit within Alba that handles the hot metal and cast it into Alba's finished products.

**CO<sub>2</sub>e**

Carbon dioxide equivalent is a standard unit for measuring carbon footprints.

**Coal Tar Pitch Volatiles (CTPV)**

Substances that are composed of various chemical vapours that become airborne during the heating of coal tar pitch.

**Copper**

An element added to aluminium for improving mechanical properties.

**Cryolite**

It consists of fluoride of sodium and aluminium and is added to bauxite as a flux in aluminium smelting.

**Cyanide**

Extremely poisonous compounds  
e.g. potassium cyanide.

**EC Rod**

Electrical conductor rods.

**Fluoride**

A compound that has an adverse impact on environment.

**Hydrogen Fluoride (HF)**

A colourless corrosive gas, HF, the anhydride of hydrofluoric acid, which is used primarily as a catalyst and in the fluorination of hydrocarbons.

**IPO**

Initial Public Offering.

**Iron**

An element added to aluminium for improving mechanical properties. Also one of the impurities in aluminium.



**ISO 14001:2004**

The international standard for Environmental Management Systems (EMS).

**ISO 9001**

The international standard that specifies requirements for a Quality Management System (QMS).

**kA**

Kilo Ampere is a higher unit of the current.

**Liquid Pitch**

A thick, black, viscous liquid formed during the distillation of coal.

**Magnesium**

An element added to aluminium for improving mechanical properties.

**MI**

Abbreviation for megalitre - a metric unit of capacity equal to a million litres.

**MMBTU**

Abbreviation for one million British Thermal Units (BTU). A BTU is a measure of the energy content in fuel, and is used in the power and steam industries. One BTU is equivalent to 1.06 Joules.

**MW**

Abbreviation for megawatt. A unit of power equivalent to one million watts.

**MWh**

Abbreviation for megawatt hour. A megawatt is equal to 1,000 Kilowatt hours.

**MW ISO**

It is the standard condition of power produced (megawatts) which involves three standard conditions: Ambient Temperature - 15°C, Relative Humidity - 60% and Ambient Pressure at sea level.

**Nitrous Oxide**

A poisonous gas.

**OHSAS 18001:2007**

An Occupational Health and Safety Management Certification that is an international standard which provides a framework to identify, control and decrease the risks associated with Health and Safety within the workplace.

**Oxygen**

A gas that exists in nature.

**Ozone**

A colourless gas which is a form of oxygen. The layer of ozone high above the earth's surface is best known for its role in screening the Earth from harmful ultraviolet rays from the sun.

**Particulate Matter**

The sum of all solid and liquid particles suspended in air many of which are hazardous.

**Perfluorocarbons**

Any hydrocarbon derivative in which all hydrogen atoms have been replaced with fluorine.

**Reduction Line (Potline)**

The production line in aluminium smelters which produces aluminium by electrolysis.

**Silicon**

An element added to aluminium for improving mechanical properties. Also one of the impurities in aluminium.

**t/a, mt/a**

Abbreviation for metric tonnes per annum.

**t, mt**

Abbreviation for metric tonnes. A unit of weight equivalent to 1,000 kilograms.

**Titanium**

An element added to aluminium for improving mechanical properties.

**Tranche**

One part or division of a larger unit, as of an asset pool or investment.

**Volatile Organic Compound (VOC)**

Any compound of carbon, excluding carbon monoxide, carbon dioxide, carbonic acid, metallic carbides or carbonates and ammonium carbonate, which participates in atmospheric photochemical reactions.

## GRI Content Index

GRI Standard	Disclosure	Internal / External Boundary (I/E)	Page / Reference or more information
<b>GRI 101: Foundation 2016</b>			
<b>General Disclosures</b>			
<b>GRI 102: General Disclosures</b>	<b>Organisational Profile</b>		
	102-1: Name of the organisation	N/A	Front Cover
	102-2: Activities, brands, products and services	N/A	p.10
	102-3: Location of headquarters	N/A	p.8
	102-4: Location of operations	N/A	p.8
	102-5: Ownership and legal form	N/A	p.8
	102-6: Markets served	N/A	p.11
	102-7: Scale of the organisation	N/A	pp.8, 9, 11, 12
	102-8: Information on employees and other workers	N/A	pp.49, 50
	102-9: Supply Chain	N/A	p.28
	102-10: Significant changes to the organisation and its supply chain	N/A	There were no significant changes
	102-11: Precautionary Principle or approach	N/A	p.30
	102-12: External initiatives	N/A	p.17
	102-13: Membership of associations	N/A	p.17
	<b>Strategy</b>		
	102-14: Statement from senior decision-maker	N/A	p.6
	<b>Ethics and Integrity</b>		
	102-16: Values, principles, standards and norms of behaviour	N/A	pp.23, 24
	<b>Governance</b>		
	102-18: Governance structure	N/A	p.25
	<b>Stakeholder Engagement</b>		
	102-40: List of stakeholder groups	N/A	p.15
	102-41: Collective bargaining agreements	N/A	Collective bargaining agreements are not applicable to Alba
	102-42: Identifying and selecting stakeholders	N/A	pp.14, 15
	102-43: Approach to stakeholder engagement	N/A	pp.14, 15
	102-44: Key topics and concerns raised	N/A	Outcomes of the stakeholder engagement plan will be outlined in the FY2018 report
	<b>Reporting Practice</b>		
	102-45: Entities included in the consolidated financial statements	N/A	Bahrain and United States sales office
	102-46: Defining report content and topic boundaries	N/A	p.7
	102-47: List of material topics	N/A	p.16
	102-48: Restatements of information	N/A	OHS data from FY2016 has been recalculated
	102-49: Changes in reporting	N/A	Some additional material topics have been identified in the FY2017 report
102-50: Reporting period	N/A	p.7	
102-51: Date of most recent report	N/A	FY2016	
102-52: Reporting cycle	N/A	Annual	
102-53: Contact point for questions regarding the report	N/A	p.62	
102-54: Claims of reporting in accordance with the GRI Standards	N/A	p.7	
102-55: GRI Content Index	N/A	pp.58-61	
102-56: External assurance	N/A	p.7	

GRI Standard	Disclosure	Internal / External Boundary (I/E)	Page / Reference or more information
<b>Specific Disclosures: Material Topics</b>			
<b>GRI 200: Economic</b>			
<b>GRI 103: Management Approach 2016</b>	103-1: Explanation of the material topic and its Boundary	I	p.12
	103-2: The management approach and its components	I	p.12
	103-3: Evaluation of the management approach	I	p.12
<b>GRI 201: Economic Performance 2016</b>	201-1: Direct economic value generated and distributed	I/E	p.12
<b>GRI 103: Management Approach 2016</b>	103-1: Explanation of the material topic and its Boundary	I/E	p.28
	103-2: The management approach and its components	I/E	p.28
	103-3: Evaluation of the management approach	I/E	p.28
<b>GRI 204: Procurement Practices 2016</b>	204-1: Proportion of spending on local suppliers	I/E	p.28
<b>GRI 103: Management Approach 2016</b>	103-1: Explanation of the material topic and its Boundary	I/E	p.24
	103-2: The management approach and its components	I/E	p.24
	103-3: Evaluation of the management approach	I/E	p.24
<b>GRI 205: Anti-corruption 2016</b>	205-1: Operations assessed for risks related to corruption	I/E	p.24
	205-2: Communications and training about anti-corruption policies and procedures	I/E	p.23
	205-3: Confirmed incidents of corruption and actions taken	I	p.24
<b>GRI 103: Management Approach 2016</b>	103-1: Explanation of the material topic and its Boundary	I	p.25
	103-2: The management approach and its components	I	p.25
	103-3: Evaluation of the management approach	I	p.25
<b>GRI 206: Anti-competitive Behaviour</b>	206-1: Legal actions for anti-competitive behaviour, anti-trust and monopoly practices	I	p.25

*continued over*

## GRI Content Index

GRI Standard	Disclosure	Internal / External Boundary (I/E)	Page / Reference or more information
<b>Specific Disclosures: Material Topics</b>			
<b>GRI 300: Environmental</b>			
<b>GRI 103: Management Approach 2016</b>	103-1: Explanation of the material topic and its Boundary	I	pp.30, 32
	103-2: The management approach and its components	I	pp.30, 32
	103-3: Evaluation of the management approach	I	pp.30, 32
<b>GRI 301: Materials 2016</b>	301-1: Materials used by weight or volume	I	p.34
	301-2: Recycled input materials used	I	p.32
<b>GRI 103: Management Approach 2016</b>	103-1: Explanation of the material topic and its Boundary	I	pp.30, 36
	103-2: The management approach and its components	I	pp.30, 36
	103-3: Evaluation of the management approach	I	pp.30, 36
<b>GRI 302: Energy 2016</b>	302-1: Energy consumption within the organisation	I	p.36
	302-3: Energy intensity	I	p.36
	302-4: Reduction of energy consumption	I	p.36
<b>GRI 103: Management Approach 2016</b>	103-1: Explanation of the material topic and its Boundary	I	pp.30, 38
	103-2: The management approach and its components	I	pp.30, 38
	103-3: Evaluation of the management approach	I	pp.30, 38
<b>GRI 303: Water 2016</b>	303-1: Water withdrawal by source	I	Data on water withdrawal has not been included due to uncertainty in calculation figures. We will amend our calculation methodology and report on this in FY2018.
	303-3: Water recycled and reused	I	p.38
<b>GRI 103: Management Approach 2016</b>	103-1: Explanation of the material topic and its Boundary	I/E	pp.30, 40
	103-2: The management approach and its components	I/E	pp.30, 40
	103-3: Evaluation of the management approach	I/E	pp.30, 40
<b>GRI 305: Emissions</b>	305-1: Direct (Scope 1) GHG emissions	I	p.41
	305-4: GHG emissions intensity	I	p.41
	305-7: Nitrogen oxides (NO <sub>x</sub> ), sulphur oxides (SO <sub>x</sub> ) and other significant air emissions	I	p.41
<b>GRI 103: Management Approach 2016</b>	103-1: Explanation of the material topic and its Boundary	I/E	pp.30, 42
	103-2: The management approach and its components	I/E	pp.30, 42
	103-3: Evaluation of the management approach	I/E	pp.30, 42
	306-2: Waste by type and disposal method	I/E	p.43
	306-3: Significant spills	I/E	p.42
	306-4: Transport of hazardous waste	I/E	p.42
<b>GRI 103: Management Approach 2016</b>	103-1: Explanation of the material topic and its Boundary	I/E	p.26
	103-2: The management approach and its components	I/E	p.26
	103-3: Evaluation of the management approach	I/E	p.26
<b>GRI 307: Environment Compliance 2016</b>	307-1: Non-compliance with environmental laws and regulations	I/E	p.26
<b>GRI 103: Management Approach 2016</b>	103-1: Explanation of the material topic and its Boundary	I/E	p.28
	103-2: The management approach and its components	I/E	p.28
	103-3: Evaluation of the management approach	I/E	p.28
<b>GRI 307: Supplier Environment Assessment 2016</b>	308-1: New suppliers that were screened using environmental criteria	I/E	p.28

GRI Standard	Disclosure	Internal / External Boundary (I/E)	Page / Reference or more information
<b>Specific Disclosures: Material Topics</b>			
<b>GRI 400: Social</b>			
<b>GRI 103: Management Approach 2016</b>	103-1: Explanation of the material topic and its Boundary	I	p.48
	103-2: The management approach and its components	I	p.48
	103-3: Evaluation of the management approach	I	p.48
<b>GRI 401: Employment 2016</b>	401-1: New employee hires and employee turnover	I	p.50
	401-2: Benefits provided to full-time employees that are not provided to temporary or part-time employees	I	p.49
	401-3: Parental leave	I	p.50
<b>GRI 103: Management Approach 2016</b>	103-1: Explanation of the material topic and its Boundary	I	p.55
	103-2: The management approach and its components	I	p.55
	103-3: Evaluation of the management approach	I	p.55
<b>GRI 402: Labour and Management Relations 2016</b>	402-1: Minimum notice periods regarding operational changes	I	Employees receive a minimum one month notice regarding policy amendments and operational changes
<b>GRI 103: Management Approach 2016</b>	103-1: Explanation of the material topic and its Boundary	I/E	pp.44, 46
	103-2: The management approach and its components	I/E	pp.44, 46
	103-3: Evaluation of the management approach	I/E	pp.44, 46
<b>GRI 403: Occupational Health &amp; Safety 2016</b>	403-2: Types of injury and rates of injury, occupational diseases, lost days, and absenteeism and number of work related fatalities	I	p.46
<b>GRI 103: Management Approach 2016</b>	103-1: Explanation of the material topic and its Boundary	I	pp.53, 54
	103-2: The management approach and its components	I	pp.53, 54
	103-3: Evaluation of the management approach	I	pp.53, 54
<b>GRI 404: Training and Education 2016</b>	404-1: Average hours of training per year per employee	I	p.54
<b>GRI 103: Management Approach 2016</b>	103-1: Explanation of the material topic and its Boundary	I/E	p.52
	103-2: The management approach and its components	I/E	p.52
	103-3: Evaluation of the management approach	I/E	p.52
<b>GRI 412: Human Rights 2016</b>	412-2: Employee training on human rights policies or procedures	I/E	p.23
<b>GRI 103: Management Approach 2016</b>	103-1: Explanation of the material topic and its Boundary	I/E	p.28
	103-2: The management approach and its components	I/E	p.28
	103-3: Evaluation of the management approach	I/E	p.28
<b>GRI 414: Supplier Social Assessment</b>	414-1: New suppliers that were screened using social criteria	I/E	p.29
<b>GRI 103: Management Approach 2016</b>	103-1: Explanation of the material topic and its Boundary	I/E	p.26
	103-2: The management approach and its components	I/E	p.26
	103-3: Evaluation of the management approach	I/E	p.26
<b>GRI 419: Socio economic Compliance 2016</b>	419-1: Non-compliance with laws and regulations in the social and economic area	I/E	p.26
<b>GRI G4 Mining and Metals Sector Disclosure</b>			
<b>Materials Stewardship</b>	Disclosure on Management Approach	I/E	p.32

### Further information

Our 2017 and past Annual Reports are available at:

<http://www.albasmelter.com/IR/Publications/Pages/default.aspx>

Hard copies of this report are available upon request. Please contact us for a copy to be sent to you.

You can follow us on a variety of social media platforms.

To connect with us, please use the following links:

[www.facebook.com/Alba4World](http://www.facebook.com/Alba4World)  
[www.twitter.com/Alba4World](http://www.twitter.com/Alba4World)  
[www.youtube.com/Alba4World](http://www.youtube.com/Alba4World)  
[www.flickr.com/Alba4World](http://www.flickr.com/Alba4World)  
[www.slideshare.com/Alba4World](http://www.slideshare.com/Alba4World)  
[www.instagram.com/Alba4World](http://www.instagram.com/Alba4World)  
<https://www.linkedin.com/company/97649>

You can also contact us at:

Aluminium Bahrain B.S.C. (Alba)  
P.O. Box 570  
Kingdom of Bahrain  
Telephone: +973 1783 0000  
Facsimile: +973 1783 0083  
Official website: <http://albasmelter.com>

For Sustainability Reporting feedback and enquiries, please email us directly at:  
[IR@alba.com.bh](mailto:IR@alba.com.bh)



**Aluminium Bahrain B.S.C. (Alba)**

P.O. Box 570  
Kingdom of Bahrain  
Telephone: +973 1783 0000  
Facsimile: +973 1783 0083  
Internet: <http://albasmelter.com>

This report is printed on 100% recycled stock